



# Porsche Mobile Charger Plus

Good to know – Driver's Manual

06/2023

Porsche, the Porsche Crest, Panamera, Cayenne and Taycan are registered trademarks of Dr. Ing. h.c. F. Porsche AG.

Printed in Germany.

Reprinting – even of excerpts – or duplication of any kind are only permissible with the written authorisation of Dr. Ing. h.c. F. Porsche AG.

© Dr. Ing. h.c. F. Porsche AG

Porscheplatz 1

70435 Stuttgart

Germany

### Driver's Manual

Always keep this operating manual and hand it over to the new owner if you sell your charger. Due to different requirements in various countries, the information in the thumb index tabs of this manual will be different. To ensure that you are reading

the thumb index tab that applies to your country, compare the article number of the charger shown in the "Technical Data" section with the article number on the identification plate on the charger.

### Suggestions

Do you have any questions, suggestions or ideas regarding your vehicle or this manual?

Please write to us:

Dr. Ing. h.c. F. Porsche AG

Vertrieb Customer Relations

Porscheplatz 1

70435 Stuttgart

Germany

### Equipment

Because our vehicles undergo continuous development, equipment and specifications may not be as illustrated or described by Porsche in this manual. Items of equipment are not always according to the standard scope of delivery or country-specific vehicle equipment

For more information on retrofit equipment, please contact a qualified specialist workshop. Porsche recommends a Porsche partner as they have trained workshop personnel and the necessary parts and tools.

Because of different legal requirements in individual countries, the equipment in your vehicle may vary from what is described in this manual. If your Porsche is fitted with any equipment not described in this manual, your qualified specialist workshop will be glad to provide information on the correct operation and care of the items concerned.

# About this Owner's Manual

## Warning notices and symbols

Various types of Warning notices and symbols are used in this Driver's Manual.



**DANGER**

Serious injury or death

Failure to observe Warning notices in the "Danger" category will result in serious injury or death.



**WARNING**

Possible serious injury or death

Failure to observe Warning notices in the "Warning" category can result in serious injury or death.



**CAUTION**

Possible moderate or minor injury

Failure to observe Warning notices in the "Caution" category can result in moderate or minor injuries.

**NOTICE**

Possible vehicle damage

Failure to observe Warning notices in the "Notice" category can result in damage to the vehicle.



**Information**

Additional information is indicated by "Information".

- ✓ Conditions that must be met in order to use a function.
- ▶ Instruction that you must follow.

1. If an instruction comprises several steps, these are numbered.

2. Instructions that you must follow on the central display.

▶ Notice on where you can find further important information on a topic.

## Further Information

You can access the full Driver's Manual at the following web address:

<https://tinyurl.com/porsche-e-help>



## Table of contents

### To the Driver's Manual

Key to pictograms.....	3
Further Information.....	3

### Security

Safety instructions.....	4
Proper use.....	5

### Scope of delivery

Access data.....	6
------------------	---

### Overview

Possible uses.....	7
Connections on the control unit.....	9
Control unit.....	9

### Requirements and conditions

Selecting the installation location.....	9
Required tools.....	10

### Installing

Installing the wall mount.....	10
--------------------------------	----

### Set up

Vehicle charging cables and supply cables.....	11
Initial operation and configuration.....	15
Initial operation.....	18
Overview.....	18

### Operating

Operating instructions.....	19
Charge.....	19
Logging into the web application.....	21
Using the web application.....	22

<b>Malfunctions.....</b>	<b>25</b>
--------------------------	-----------

<b>Transport.....</b>	<b>30</b>
-----------------------	-----------

<b>Cleaning and maintenance.....</b>	<b>30</b>
--------------------------------------	-----------

<b>Disposal.....</b>	<b>30</b>
----------------------	-----------

### Technical Data

Identification plate.....	32
Production information.....	32
Importers.....	33

<b>Index.....</b>	<b>34</b>
-------------------	-----------

## To the Driver's Manual

### Key to pictograms

Depending on the country, various pictograms may be attached to the charger.

 Operate the charger within a temperature range from -30 °C to +50 °C.

 The charger should not be operated at altitudes of more than 5,000 m above sea level.

 The charger is equipped with a non-switched protective conductor.

 The charger is equipped with a switched protective conductor.



 Dispose of the charger in compliance with all applicable disposal regulations.



 Do not use extension cables or cable reels.



 Do not use (travel) adapters.

 Do not use multiple sockets.

 Do not use chargers with damaged electronics or connecting cables.

  Risk of electric shock due to improper use.

  Observe the operating instructions provided, particularly the warnings and safety instructions.

   The surface of the charger can become very hot.

 Do not operate the charger in non-earthed mains supply systems, e.g. IT networks. Operate the charger only in earthed mains supply systems.

 Indicates the type 1 plug with a voltage range  $\leq 250$  V AC.

 Indicates the type 2 plug with a voltage range  $\leq 480$  V AC.

### Further Information

You will find further information on the charger and the Web Application in the "E-Performance" area at <https://www.porsche.com>.

## Security

### Safety instructions

**⚠ DANGER**

Electric shock, short circuit, fire, explosion

Use of a damaged or defective charger and a damaged or defective electrical socket, improper use of the charger or failure to observe the safety instructions can cause short circuits, electric shocks, explosions, fires or burns.

- ▶ Only use accessories, e.g. power supply and vehicle cables, that have been approved and supplied by Porsche.
- ▶ Do not use a damaged and/or soiled charger. Check the cable and plug connection for damage and soiling before use.
- ▶ Only connect the charger to properly installed and undamaged electrical sockets and fault-free electrical installations.
- ▶ Do not use extension cables, cable reels, multiple sockets or (travel) adapters.
- ▶ Disconnect the charger from the mains supply during thunderstorms.
- ▶ Do not modify or repair any of the electrical components.
- ▶ Have faults corrected and repairs performed by experts only.

**⚠ DANGER**

Electric shock, fire

Incorrectly installed electrical sockets can cause electric shock or fire when the high-voltage battery is charged using the vehicle charge port.

- ▶ Power supply testing and installation and initial operation of the electrical socket for the charger must only be carried out by a qualified electrician. This person is fully responsible for compliance with the relevant standards and regulations. Porsche recommends that you use a certified Porsche service partner.
- ▶ The cross-section of the power cable for the electrical socket must be defined in accordance with the wire length and the locally applicable regulations and standards.
- ▶ The electrical socket used for charging must be connected to a separately fused electric circuit that complies with local laws and standards.
- ▶ The charger is intended for use in private and semi-public areas, e.g. private properties or company car parks. In some countries, e.g. in Italy and New Zealand, mode 2 charging is **prohibited** in public areas.
- ▶ Unauthorised persons (e.g. playing children) or animals must not have access to the charger and the vehicle during unsupervised charging.
  - ▷ Always read the safety instructions in the installation manual and the Driver's Manual.

**⚠ DANGER**

Electric shock, fire

Incorrect handling of the plug contacts can lead to electric shock or fire.

- ▶ Do not touch the contacts on the vehicle charge port and charger.
- ▶ Do not insert any objects into the vehicle charge port or charger.
- ▶ Protect electrical sockets and plug connections against moisture, water and other liquids.

**⚠ WARNING**

Flammable or explosive vapours

Components of the charger can cause sparks and ignite flammable or explosive vapours.

- ▶ To reduce the risk of explosion – particularly in garages – make sure that the control unit is located at least 50 cm above the floor during charging.
- ▶ Do not install the charger in potentially explosive atmospheres.

To fulfil the requirements limiting exposure to electromagnetic radiation (1999/519/EC), install the charger with a minimum distance from all persons of 20 cm.

Observe the following instructions and recommendations in order to guarantee uninterrupted charging with the charger:

- When installing a new electrical socket, select an industrial electrical outlet with the highest possible power available (adapted to the domestic electric installation) and have it put into op-

eration by a qualified electrician. Porsche recommends that you use a certified Porsche service partner.

- Where technically possible and legally permissible, the electric installation must be dimensioned in such a way that the maximum nominal power of the electrical socket used is available for charging the vehicle.
- Before installation, check that the necessary power for charging a vehicle can be continuously provided with the currently available domestic installation. If necessary, protect the domestic installation with an energy management system.
- The charger should preferably be operated in earthed mains supply systems. The protective conductor lead must be properly installed.
- If you are unsure about the electrical domestic installation, contact a qualified electrician. Porsche recommends that you use a certified Porsche service partner.
- If you intend to use the charger with a photovoltaic system, contact a Porsche partner.
- In order to make full use of the charger and to ensure fast vehicle charging, use either NEMA electrical sockets with the highest possible current rating appropriate for the power plug or industrial electrical outlets to IEC 60309.
- When charging the high-voltage battery via the household/industrial electrical outlet, the electrical installation may be loaded to its maximum capacity. Porsche recommends that you have electrical installations used for charging checked regularly by a qualified electrician. Ask a qualified

electrician which inspection intervals are appropriate for your installation. Porsche recommends that you use a certified Porsche service partner.

- To prevent overheating of the electrical installation, the charging current for household cables is automatically limited on delivery. Have a qualified electrician bring the charger into operation and set the charging current limit as required for the domestic installation.
  - ▶ Refer to chapter "Charging current limiting" on page 20.

## Proper use

Charger with integrated control and protection for the mode 2 charging to charge vehicles with high-voltage batteries that meet the generally applicable standards and directives for electric vehicles.

- ▶ Always use the appropriate device version for the local mains supply.
  - ▶ Refer to chapter "Technical Data" on page 31.

The charger may only be used in combination with supply cable, control panel and vehicle cable.

It is suitable for use outdoors.

- ✓ Norway:

Mobile chargers must only be used for occasional charging. For indicated charging points, a fixed installation by a qualified electrician is required.

## Scope of delivery



Fig. 1: Scope of delivery

- A** Supply cable (permanently attached to the control panel or detachable)
- B** Power plug for connecting to the mains supply
- C** Control panel
- D** Vehicle plug (connector plug for the vehicle), differs depending on country (type 2 shown)
- E** Vehicle cable (permanently attached to control panel)
- F** Letter containing access data

### **i** Information

Optional components: Various wall mounts are available for the charger, depending on country, e.g. the basic wall mount.

### Access data

A letter containing access data, which contains all the data you need for the charger and the Web Application, is supplied with your device.

- ▶ Keep the letter containing access data in a safe place.

#### Information

If lost, the access data valid upon delivery, such as the initial password, can be obtained from a Porsche partner.

- Have the serial number of the charger ready.

Designation	Meaning
Serial number	Serial number of the charger
Security ID	For secure connection with the PLC modem
MAC	MAC address of home network PLC interface
Web password	Initial password for the Web Application
Web host name	For connecting to the Web Application via a web browser
PUK	Personal unlocking key

### PUK

The PUK serves to reactivate the initial password.

- ▶ If you lose or forget the PUK, contact your Porsche partner.

#### Information

The security field contains the unlocking key (PUK). This field is printed over with a special ink that covers the PUK.

Only after moistening this field under running water does the ink fade, making the PUK visible. Do not rub or scratch the field while dampening it, as the PUK could otherwise be damaged.

### Web application password

The password is used for logging into the Web Application.

When using the initial password:

- ▶ If you lose or forget the initial password, contact your Porsche partner.

When using a password you set yourself:

- ▶ If lost, the initial password can be restored using the PUK. Alternatively, please contact a Porsche partner.
- ▶ By resetting the charger to the factory settings, the initial password is reactivated. However, this causes all settings to be reset to the factory settings.

### Serial number of the charger

The serial number of the charger can be found in the following places:

- In the letter containing access data after the designation **Serial number**
- On the identification plate (on the back of the control unit) after the abbreviation **SN**
- In the Web Application: **Settings**  ▶ **Maintenance** ▶ **Device information**

### Resetting to factory settings

All your settings will be deleted if you activate this function. Moreover, all passwords will be reset to the initial passwords indicated in the letter containing your access data.

#### Information

This function is deactivated as standard in the charger. In order to execute this function in the charger, it must be enabled in the Web Application (**Settings**  ▶ **System** ▶ **Allow reset to factory settings**).

1. Press and hold the **CHARGE STATUS** button and the **MULTI-FUNCTION BUTTON** simultaneously for 5 seconds. The **CHARGER** indicator light flashes white when you do so.
2. As soon as the **CHARGER** indicator light stops flashing, release the **MULTI-FUNCTION BUTTON** and keep the **CHARGE STATUS** button pressed for 2 seconds.



- Press and hold the **MULTI-FUNCTION BUTTON** again for 5 seconds.

The **CHARGER** indicator light flashes white when you do so.

- ➔ The charger is reset to the factory settings. In the meantime, the indicator lights light up green.

The device is ready for operation once the self-test has been completed successfully.

Resetting to factory settings is also possible via the web application or at a qualified specialist workshop. Porsche recommends a Porsche partner as they have trained workshop personnel and the necessary parts and tools.

For information on the Web Application, see the instructions at <https://www.porsche.com/international/about-porsche/e-performance/help-and-contact/>

If you require a different language, please select the appropriate website for your country.

## Overview

### Possible uses

The charger can be used in standalone operation and operated via the buttons. The Powerline-Communication functionalities of the charger enable connection to be established to the home network. For this to happen, the existing mains supply is used to set up a local network for data transfer. The PLC connection is a prerequisite for operation via the Web Application of the charger or control via the energy manager.

Possible uses	Operating the Porsche Mobile Charger Plus	Where?
<b>Variante 1</b>	Operation is performed directly at the charger (standalone operation)	▷ P. 7
<b>Variante 2</b>	Operation is performed via the Web Application of the charger (without energy manager). A home network (PLC connection) is required to establish a connection.	▷ P. 7
<b>Variante 3</b>	Operation is performed via the Web Application of the energy manager. The energy manager is registered as a client in the PLC network.	▷ P. 8
<b>Variante 4</b>	Operation is performed via the Web Application of the energy manager. The charger and the energy manager connect directly via the DHCP server of the energy manager.	▷ P. 8

### Variante 1: Standalone operation

In standalone operation, no connection via a network is required. Convenient operation and configuration of the charger via the Web Application is not used in this variant. Instead, the charger is operated directly using the buttons on the device. For limiting the charging current, the settings **50 %** or **100 %** are available.

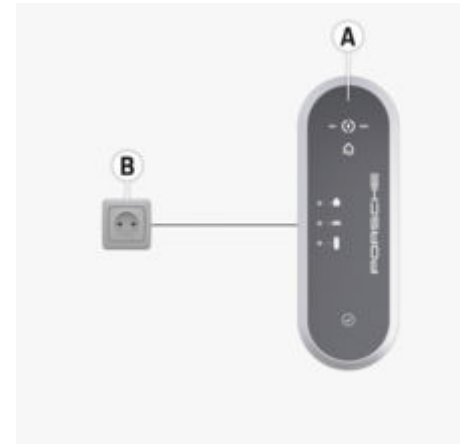

Fig. 2: Standalone operation (application example)

- A** Porsche Mobile Charger Plus
- B** Electrical socket

### Variante 2: Operation via the Web Application of the charger

The Web Application can be opened in the browser on a device (PC, tablet or smartphone) that is logged into the same home network as the charger.

A home network in which the charger and device must be located is required to establish a connection. A network connection can be established directly via PLC (Powerline Communication). The device and charger are connected via a PLC adapter and a router. The device can access the Web Application of the charger via the router.

The charger can however still be operated using the buttons on the device. For limiting the charging current, the settings **50 %** or **100 %** are available.

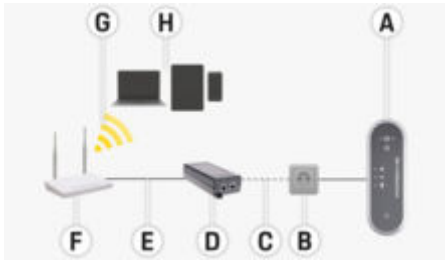

Fig. 3: Operation via the web application of the charger (without energy manager) (application example)

- A Porsche Mobile Charger Plus
- B Electrical socket
- C Network connection via power line (PLC)
- D PLC adapter
- E Network connection via Ethernet
- F Router
- G WiFi
- H Mobile device

### Variant 3: Operation of charger and energy manager in the same PLC network

If an energy manager is used, the charging current is limited via the energy manager.

To establish a connection, the energy manager, charger and device must be located within the same home network.

In this configuration, the charger and energy manager each connect to a router via PLC (Powerline Communication), the energy manager optionally directly via Ethernet or WiFi. The Web Application of the energy manager and of the charger can be accessed by the device via the router.

Operation of the charger via the buttons on the device or via the Web Application of the charger remains possible. In this case, however, the energy manager settings for limiting the charging current are overruled.

▷ Refer to chapter "Energy manager" on page 16.

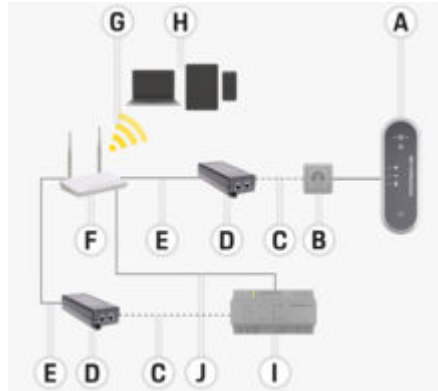

Fig. 4: Connection of the charger and energy manager via a router (application example)

- A Porsche Mobile Charger Plus
- B Electrical socket
- C Network connection via power line (PLC)
- D PLC adapter
- E Network connection via Ethernet
- F Router
- G WiFi
- H Mobile device
- I Energy manager
- J Network connection via Ethernet (alternative)

### Variant 4: Direct connection of the charger and energy manager via PLC

Because the energy manager features an integrated PLC adapter, the connection between the charger and the energy manager can also take place directly via PLC. Connection of the energy manager to the router then once again takes place via WiFi, PLC or Ethernet.

With the mobile device, access to the Web Application of the energy manager (and charger) then takes place as in variants 2 and 3 via the router. Operation of the charger via the buttons on the device or via the Web Application of the charger remains possible. In this case, however, the energy manager settings for limiting the charging current are overruled.

▷ Refer to chapter "Energy manager" on page 16.

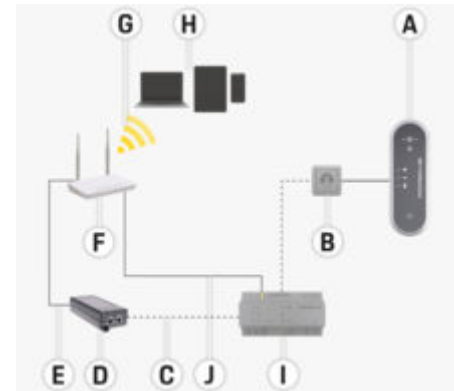

Fig. 5: Direct connection of the charger and energy manager via PLC (application example)

- A Porsche Mobile Charger Plus
- B Electrical socket
- C Network connection via power line (PLC)
- D PLC adapter

- E** Network connection via Ethernet
- F** WiFi router
- G** WiFi
- H** Mobile device
- I** Energy manager
- J** Network connection via Ethernet (alternative)

## Connections on the control unit



Fig. 6: Connections on the control unit

- A** Supply cable
- B** Vehicle cable

The supply cable **A** can be removed and inserted at the top of the control unit.

The vehicle cable **B** is removed and inserted at the bottom of the control unit.

## Control unit

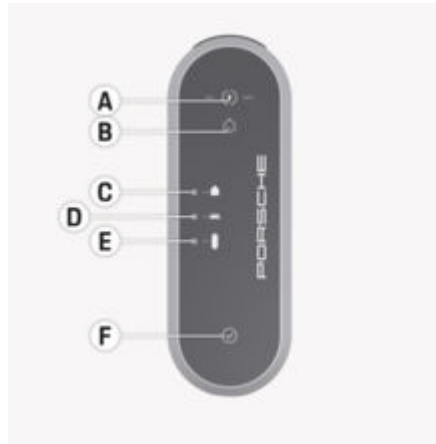

Fig. 7: Control unit

- A** **CHARGE STATUS** button with **50 %** and **100 %** indicator lights
- B** **ENERGY MANAGER** indicator light
- C** **DOMESTIC CONNECTION** indicator light
- D** **VEHICLE** indicator light
- E** **CHARGER** indicator light
- F** **MULTI-FUNCTION BUTTON**

The **CHARGE STATUS** button is used to select between a charging power of 50 % or 100 %, or to switch to energy manager mode. If an energy manager is available when in energy manager mode, a connection to the energy manager is established and its configured charging power is adopted.

The following device functions can be set using the **MULTI-FUNCTION BUTTON**, partly in combination with other buttons:

- Skip reconnection to the energy manager
- Activate and deactivate ground monitoring
- Reset to factory settings
- Reset circuit-breaker error

The **A** and **F** buttons and the **B–E** indicator lights indicate the operating state of the control unit and possible faults through various colours, lights and flashing.

- ▷ Refer to chapter "Malfunctions" on page 25.
- ▷ Refer to chapter "Charging current limiting" on page 20.

## Requirements and conditions

### Selecting the installation location

**⚠ DANGER**

Electric shock, fire

Improper use of the charger or non-compliance with the safety instructions may result in short circuits, electric shocks, explosions, fire or burns.

- ▶ Do not install the basic wall mount in potentially explosive atmospheres.
- ▶ To reduce the risk of explosion - particularly in garages - make sure that the control unit is located at least 50 cm above the floor during charging.
- ▶ Observe the locally applicable electrical installation regulations, fire protection measures, accident prevention regulations and escape routes.

The basic wall mount is designed for indoor and outdoor installation.

## Installing

The following criteria must be considered when selecting a suitable installation location:

- Install the electrical socket and basic wall mount preferably in a covered area protected against direct sunlight and rain (e.g. in a garage).
  - Do not spray the basic wall mount directly with water (e.g. high-pressure cleaning equipment or garden hoses)
  - Do not install the basic wall mount under suspended or hanging objects.
  - Do not install the basic wall mount in stables, livestock buildings or locations where ammonia gases occur.
  - Install the basic wall mount on a smooth surface.
  - In order to ensure secure fastening, check the condition of the wall before installing.
  - Install the basic wall mount so that it is not near pathways and the charging cables do not cross any pathways.
  - Install the basic wall mount so that the distance between the plug and the socket does not exceed the length of the available supply cable.
  - Install the electrical socket as close as possible to the preferred vehicle parking position. Take the orientation of the vehicle into account.
  - The distance of the electrical socket from the floor and ceiling should be selected in compliance with national regulations and standards so that comfortable use is ensured.
- ▷ Refer to chapter "Safety instructions" on page 4.

## Required tools

- Level
- Power drill or power hammer
- Screwdriver

## Installing Installing the wall mount Installing the basic wall mount

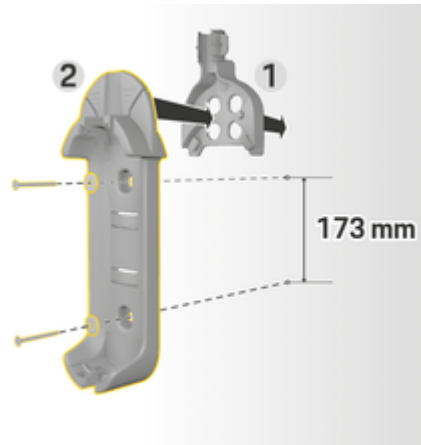

Fig. 8: Drilling dimensions

1. Mark the drill holes on the wall.
2. Drill the mounting holes and insert dowels.
3. Press the standard wall mount 2 (Fig. 8) into the cable guide 1 (Fig. 8) from the front.
4. Screw the basic wall mount onto the wall.

### **i** Information

Attach the wall mount at a height of at least 1 m.

## Installing the connector fastener

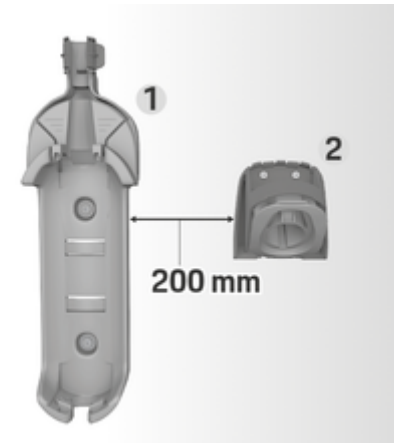

Fig. 9: Distance between wall mount and connector fastener

When installing the connector fastener, ensure a distance of 200 mm from the basic wall mount.



Fig. 10: Drilling dimensions

1. Remove the connector fastener **1** (Fig. 10) from the cover **2** (Fig. 10).
2. Mark the drill holes on the wall.
3. Drill the mounting holes and insert wall plugs.
4. Screw the connector fastener **1** (Fig. 10) onto the wall.
5. Fit the cover **2** (Fig. 10) onto the connector fastener **1** (Fig. 10) from below and push up.

## Attaching the control unit to the wall mount



Fig. 11: Attaching the control unit

1. Route the vehicle cable through the lower opening of the basic wall mount, place the bottom of the control unit on the locking tab and push back to engage.
2. Guide the supply cable through the upper opening in the basic wall mount and lock the circlip by pushing it to the left.
3. Insert the vehicle plug in the connector fastener.

## Set up

### Vehicle charging cables and supply cables

#### Information on vehicle charging cables and connectors

Different vehicle charge ports **A** and vehicle plugs **B** are available depending on the vehicle equipment.



IEC 62196-2/  
SAE-J1772-2009  
Type 1 UL/IEC

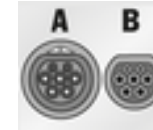

IEC 62196-2  
Type 2

### Selecting a Supply Cable

For regular charging with optimum charging speed, use only the supply cables listed below. The maximum achievable charging power is up to 11 kW (depending on the device type, national regulations, mains/household connection and on-board charger).

#### NOTICE

Use only supply cables approved for the relevant country. When driving abroad, always carry the appropriate supply cable with you for use in the country you are visiting.

Country	Supply cables for industrial electrical outlets	Supply cables for household electrical outlets
Russia, Ukraine	5, 6, 7, 8	C
Abu Dhabi, Israel, Singapore	5, 6, 7, 8	Charging not permitted at household electrical outlets
Argentina	5, 6, 7, 8	C
Bolivia, Paraguay, Uruguay, St. Martin, St. Martin	5, 6, 7, 8	B
Chile	5, 6, 7, 8	D
Peru	5, 6, 7, 8	A

Country-specific approval of Supply cables (examples)

## Supply cables for industrial electrical outlets



1. for Mexico: 12 A

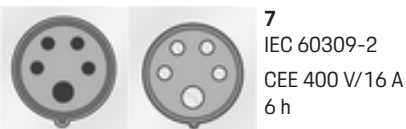
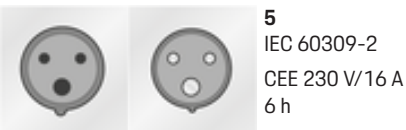

## Supply cables for household electrical outlets

If there is no industrial electrical outlet available, the supply cables listed below can also be used for charging with a reduced charging power.

- ▶ In some countries, e.g. in Abu Dhabi, Israel, Singapore and India<sup>▶</sup> P. 12, charging from household electrical outlets is **prohibited**.

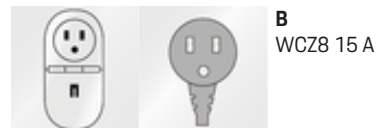



**C**  
CEE 7/5; CEE 7/7  
Type E/type F  
(Safety plug)



**D**  
BS 1363-1/EV  
Type G

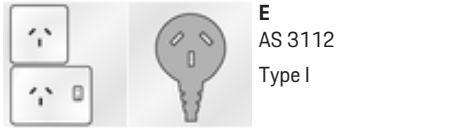

**E**  
AS 3112  
Type I

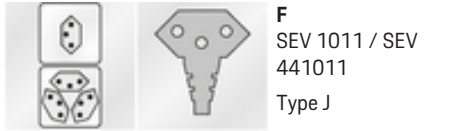

**F**  
SEV 1011 / SEV  
441011  
Type J



**G**  
DS 60884-2-D1  
Type K

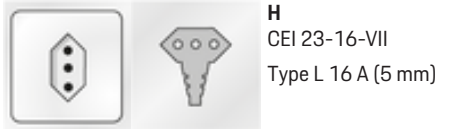

**H**  
CEI 23-16-VII  
Type L 16 A (5 mm)

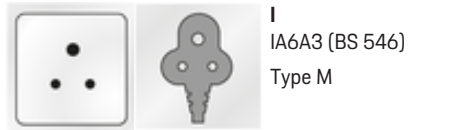

**I**  
IA6A3 (BS 546)  
Type M

**NEMA 6-50 / NEMA 14-50 (additional information)**

**i Information**

**Scope**

This usage recommendation applies only to regions with NEMA 6-50 / NEMA 14-50 standard.

Charging your vehicle may result in high electric currents. For safety reasons, it is absolutely essential that you use only components approved for this and that the entire charging equipment is installed correctly.

**General safety instructions**

**DANGER** Electric shock and fire!

Incorrect use of the charging equipment and failure to observe the installation and safety instructions can lead to a short circuit, electric shock, explosion, fire or burns.

- ▶ Pay attention to the installation instructions in the charging equipment manual.
- ▶ Pay particular attention to all safety and warning notices there.
- ▶ Have the installation carried out by a person with the necessary electrical training and specialist knowledge.
- ▶ Also observe the national regulations for carrying out electrical installations.

**Power socket requirements**

**DANGER** Unsuitable mains sockets

An unsuitable mains socket can cause a short circuit, electric shock, explosion, fire, or burns.

- ▶ Only use only a type of mains socket that is suitable for this installation (see **Suitable types of mains sockets/power plugs**).
- ▶ Only use mains sockets that meet the requirements for the quality of contact surfaces and fastening (see **Requirements for the quality of mains sockets**).
- ▶ Avoid direct contact between the terminal screws and the wire. Preferably, use wire end ferrules.
- ▶ Avoid jamming the cable on the insulation.

**Suitable mains socket/power plug types**

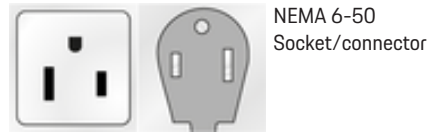

NEMA 6-50  
Socket/connector



NEMA 14-50  
Socket/connector

## Mains sockets quality requirements

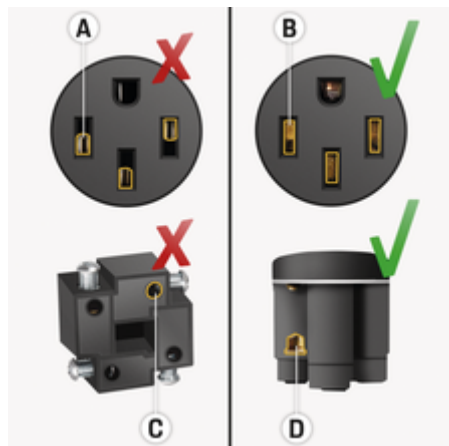

- A** Contact surface only half plug contact height
- B** Contact surface over the entire plug-in contact height
- C** Small contact surface between clamping screw and strand.
- D** Broad surface contact area between between clamping plate and strand

## Line installation requirements

**⚠ DANGER**

Unsuitable power cable

The use of unsuitable power cables or excessive electrical currents can cause a short circuit, electric shock, explosion, fire or burns.

- ▶ The cable must have a 50-amp fuse.
- ▶ Only use copper cables with a minimum cross-section of 8 AWG, or preferably 6 AWG.

1. Time of printing.

## Outdoor installation requirements

**⚠ DANGER**

Direct contact with rain

If the charging equipment is used outdoors, direct contact with rain can cause a short circuit, electric shock, explosion, fire or burns.

- ▶ Prevent the charging equipment from coming into direct contact with rain.
- ▶ Use a NEMA 3R rainproof enclosure.

## Changing the supply cable

**⚠ DANGER**

Electric shock

Risk of serious or fatal injury from electric shock.

- ▶ Disconnect the supply cable from the electrical socket before changing it.
- ▶ Only change cables in a dry environment.
- ▶ Use only cables approved by Porsche.

▶ Refer to chapter "Scope of delivery" on page 5.

In some countries, e.g. in Norway<sup>1</sup>, the supply cable may only be changed by a qualified electrician. Porsche recommends that you use a certified Porsche service partner.



Fig. 12: Connections on the control unit

The supply cable **A** can be removed and inserted at the top of the control unit.

The vehicle cable **B** is permanently connected to the control unit.



### Disconnecting the supply cable

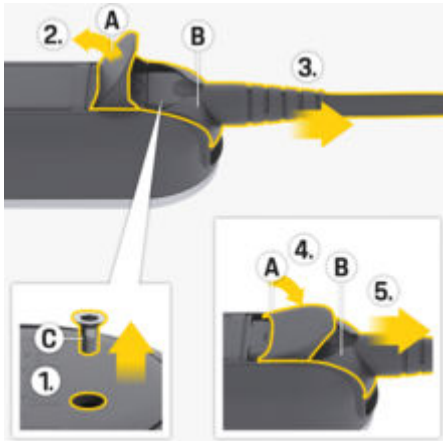

Fig. 13: Disconnecting the supply cable

- ✓ Charging of the high-voltage battery has ended and the vehicle plug has been removed from the vehicle charge port.
  - ✓ The power plug has been disconnected from the electrical socket.
1. Remove screw **C** (Fig. 13) using a suitable tool.
  2. Fully open cover **A** (Fig. 13).
  3. Pull out plug **B** (Fig. 13) until you feel initial resistance.
  4. Close cover **A** (Fig. 13) to around 15 degrees (the cover can rest on plug **B** (Fig. 13)).
  5. Pull out plug **B** (Fig. 13) fully.

### Securing the supply cable

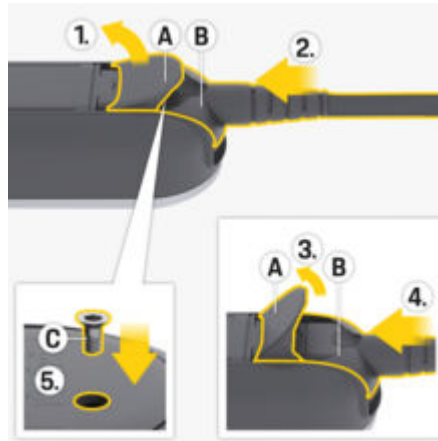

Fig. 14: Securing the supply cable and plug

1. Open cover **A** (Fig. 14) by around 15 degrees (only as far until plug **B** (Fig. 14) fits in the control unit).
2. Insert plug **B** (Fig. 14) into the control unit until you feel initial resistance.
3. Fully open cover **A** (Fig. 14).
4. Push plug **B** (Fig. 14) in fully.
5. Fully close cover **A** (Fig. 14) and fasten using screw **C** (Fig. 14).

## Initial operation and configuration

### Initial operation

- ▶ The charger conducts a self test when it is connected to the mains supply.
  - Following a successful self-test:
    - The **CHARGE STATUS** button lights up white.
    - The charger is set to the charging power of the previous charging operation. **50 %**, **100 %** and/or **50 %** indicator light lights up.
- ➔ The charger is ready for operation.

### Selecting charge status



Fig. 15: Selecting charge status

Set whether the charger is to be limited to a maximum of 50 % or 100 % of the available charging power. If an energy manager is available, you can set whether the charging power is to be specified by the energy manager.

- ✓ The charger is ready for operation.
- ▶  Press and hold the **CHARGE STATUS** button for 3 seconds.
- ➔ The charger switches to another charge status (**50 %**, **100 %** or energy manager) and the relevant indicator light lights up.

If the energy manager charge status is activated, the indicator light  pulses yellow and the charge status **50 %** lights up green. In the event of a failure of the energy manager, the charger switches to the charge status **50 %**.

For the charger to be controlled via the energy manager, it must be connected with its PLC network.

- ▶ Refer to chapter "Energy manager" on page 16.

## Energy manager

The energy manager coordinates the energy consumers and energy suppliers in the household.

For charging control to be assumed by the energy manager, the charger and energy manager must be connected to one another via a Powerline-Communication (PLC) network connection. For this to happen, the existing mains supply is used to set up a local network for data transfer.

## Adding the energy manager

There are two options for connecting the energy manager to a PLC network:

- The energy manager is registered as a client in a PLC network (application variant 3).
- Direct PLC communication between the charger and energy manager (DHCP server) (application variant 4)



- ▶ Refer to chapter "Possible uses" on page 7.





The connection between the charger and energy manager is established directly from the charger and in the Web Application of the energy manager.

## Establishing a connection to the charger

The  **ENERGY MANAGER** indicator light shows the status of the connection to the PLC network and to the energy manager.

### PLC/energy manager connection status indicator

Status display	Meaning
 Pulsing yellow	<b>Status 1</b> The charger attempts to re-establish the previously used PLC connection (maximum duration: 60 seconds).  ▶ <b>Optional:</b>  Press and hold the <b>MULTI-FUNCTION BUTTON</b> for 3 seconds to skip reconnection. The charger then searches for a new PLC network.
 Flashing yellow	<b>Status 2</b> The charger attempts to establish a connection to the new PLC network (maximum duration: 9 minutes).

Status display	Meaning
 Pulsing white	<b>Status 3</b> PLC connection is established. A connection is being established to the last known energy manager.  ▶ <b>Optional:</b>  Press and hold the <b>MULTI-FUNCTION BUTTON</b> for 3 seconds to skip reconnection.
 Flashing white	<b>Status 4</b> PLC connection is established. Connection to a new energy manager is established.
 Lights up green	<b>Status 5</b> The energy manager has been successfully connected.
 Lights up red	<b>Status 6</b> Connection could not be established.

## Ensuring good connection quality of the PLC network

To ensure a sufficient transmission rate for PLC communication, the following measures should be taken into account during electrical installation:

- ▶ If a PLC connection is not possible, test the Porsche charger in a different wall socket.
- ▶ Keep the distance between consumers with PLC functionality low. As a test, the connection to the PLC modem can be made at an electrical socket near the PLC modem (e.g. in the living room). If a connection is established here, but does not subsequently work in the garage, this may be due to the distance being too great. Please note the following information on phase assignment.
- ▶ Route the VDSL cable at a distance of at least 10 cm to the power lines and electrical sockets.
- ▶ Preferably establish the PCL connection via the same current phase.
  - If the charger is connected using a single-phase plug, the external PLC modem should be connected to the same phase as the charger in the case of a multi-phase domestic connection.
  - If the charger is connected using a multi-phase plug, the external PLC modem should be connected to phase L1.
- ▶ Check whether other electrical devices are causing interference. For this purpose, disconnect other devices from the mains supply and check the PLC connection. Possible sources of interference may be, for example, dimmers, halogen lighting systems, fridges and freezers, switched-mode power supplies, dryers, washing machines and electric pumps in operation.

## Connecting the charger to a PLC network

When establishing a connection, the charger and PLC modem, or in the case of direct PLC communication, the charger and the energy manager are paired automatically.

- ✓ The charger is ready for operation.
- ▶ Activate the charge status of the energy manager at the charger. To do this, press and hold the **CHARGE STATUS** button for 3 seconds to change the charge status. Repeat this procedure if necessary in order to change to the desired charge status. The charger automatically attempts to establish a connection to the PLC network.
  - The PLC network is known (Status 1):  
No action is necessary. The charger automatically connects to the PLC network.
  - The PLC network is unknown (Status 2):  
Press the pairing button on the PLC modem or on the energy manager to start establishing the connection to the charger.
    - ➔ If the **ENERGY MANAGER** indicator light flashes or pulses white, the charger is integrated in the PLC network and a connection is established (Status 3 or 4).

The charger automatically attempts to establish a connection to the energy manager.

▶ Refer to chapter "Connecting the charger to the energy manager" on page 17.

If no energy manager is available, establishing a connection to the energy manager fails (Status 6).

- ▶ Press and hold the **CHARGE STATUS** button for 3 seconds to switch to the desired charging status (**50 %** or **100 %**).

▶ Refer to chapter "Opening the web application" on page 22.

▶ Refer to the operating instructions of the PLC modem.

## Connecting the charger to the energy manager

### Establishing a connection at the charger

Once the charger has established a connection to the PLC network, it attempts to connect to the energy manager in open mode.

- ✓ Charger has established a PLC connection.
- ✓ The charger and energy manager are located in the same PLC network.
  - The energy manager is known (Status 3):  
No action is necessary. The charger automatically connects to the energy manager.
  - The energy manager is unknown (Status 4):  
Add the charger as an EEBus device in the Web Application of the energy manager.

If the **ENERGY MANAGER** indicator light lights up green, the energy manager is successfully connected (Status 5).

The energy manager settings (e.g. information on the charging current, overload protection and optimised charging) are adopted by the charger.

▶ The procedure for establishing the connection to the charger is described in the section "Adding an EEBus device" in the web application instructions for the Porsche Home Energy Manager.

▶ Refer to the operating instructions of the energy manager.

### Establishing a connection in the Web Application of the charger

- ▶ If the charger is in private mode, an unknown energy manager must be added in the Web Application of the charger (**Connections ▶ Energy manager**).
  - ▶ For information on the web application, see the instructions at <https://www.porsche.com/international/about-porsche/e-performance/help-and-contact/>
- If you require a different language, please select the appropriate website for your country.

### Reconnecting to the energy manager

If the charge status of the energy manager is activated, the charger automatically attempts to establish a connection to the last used PLC network.

### Hotspot

If integration in a home network is not possible, the charger can activate a hotspot and use this to establish a connection to the Web Application of the charger.

- ▶ To establish a hotspot, click **Activate hotspot**.

Once a hotspot has been established, the  symbol appears in the status bar.

#### Information

If you use an Android system, you may need to confirm separately that the connection has been established, so that a hotspot connection can be established.

## Initial operation

### Establishing a connection to the charger

Before the charger and Web Application can be put to everyday use, the charger must first be set up. Next, a connection needs to be established between your device (PC, tablet or smartphone) and the charger.

- ▶ For information on establishing the PLC connection, refer to the Porsche Mobile Charger Plus operating and installation manual.

### Requirements for initial operation in the web application

Have the following information to hand when using the Web Application for the first time:

- Access data letter of the Porsche Mobile Charger Plus for logging into the Web Application of the charger
- Access data for your home network
- Access data for your user profile (to link it with your Porsche ID)

The Web Application supports the following browsers:

- Google Chrome version 57 or later (recommended)
- Mozilla Firefox version 52 or later (recommended)
- Microsoft Internet Explorer version 11 or later
- Microsoft Edge
- Apple Safari version 10 or later

## Overview

The Web Application offers more extensive adjustment options compared to the device.

#### Information

Information on **third-party content and licences** may be accessed via the link from Web Application at any time.

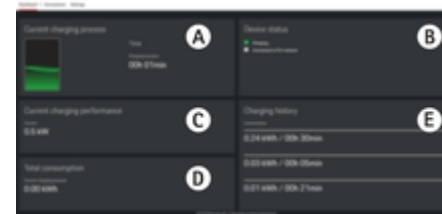

Fig. 16: Overview in the web application

#### **A Current charging process**

Shows the duration of the current charging process. If no vehicle is connected, information about the last charging process is displayed.

#### **B Device status**

Displays device information, for example:

- current charging status;
- PLC network connection status;
- energy manager connection status (if available);
- deactivation of ground monitoring;

#### **C Current charging performance**

current electrical power flow [in kilowatts] from the charger to the load;

#### **D Consumption**

total energy consumption of the current or last charging process [in kilowatt hours].

**E Charging history**

The last three charging processes are listed here chronologically. The following information is available for each charging process:

- Consumption
- Charging duration

**i Information**

Other national rules may apply regarding consumption monitoring for power determination.

## Operating

### Operating instructions

In some countries, the relevant authorities must be notified when you connect electric vehicle charging equipment.

- ▶ Check any obligations to notify the authorities, technical connection requirements (TCR) and legal requirements for operation before connecting charging equipment.

**NOTICE**

Risk of damage to the charger

- ▶ Always place the charger on a solid surface when charging.
- ▶ Porsche recommends operating the charger in the basic wall mount. In certain countries, e.g. in Switzerland<sup>1</sup>, the charger may only be operated in the basic wall mount.
  - ▷ Refer to chapter "Installing the wall mount" on page 10.

1. Time of printing. Further information is available from a qualified specialist workshop. Porsche recommends a Porsche partner as they have trained workshop personnel and the necessary parts and tools.

- ▶ Do not immerse the charger in water.
- ▶ Protect the charger from snow and ice.
- ▶ Protect the charger from potential damage due to being driven over, dropped, pulled, bent or crushed.
- ▶ Do not open the charger housing.

**NOTICE**

Damage to the charger

The charger must only be operated within a temperature range from  $-30^{\circ}\text{C}$  to  $+50^{\circ}\text{C}$ .

- ▶ To prevent overheating during operation, avoid continuous exposure of the charger to direct sunlight. If the charger overheats, charging will be interrupted automatically until the temperature has returned to the normal range.
- ▶ If the charger is too hot or too cold, let it return slowly to the operating temperature range and do not actively cool it down or heat it, e.g. by cooling it down with cold water or heating it with a hairdryer.

**Charge****Charging instructions****Vehicle charge port****DANGER**

Electric shock, fire

Risk of serious or fatal injury due to fire or electric shock.

- ▶ Always observe the specified order for the charging procedure.
- ▶ Do not unplug the vehicle cable from the vehicle charge port during charging.
- ▶ End the charging process before disconnecting the vehicle cable from the vehicle charge port.
- ▶ Do not disconnect the charger from the electrical socket during charging.

Faults are indicated by the red indicator lights.

- ▶ Refer to chapter "Malfunctions" on page 25.
  - ▷ For information on connecting and disconnecting the vehicle cable to and from the vehicle charge port and for the charging and connection status at the vehicle charge port, refer to the Driver's Manual.

**Charging times**

The charging duration can vary depending on the following factors:

- Electrical socket used (domestic electrical outlet or industrial electrical outlet)
- Country-specific mains voltage and electric current

- Settings for limiting the charging current on the charger
- Fluctuations in the mains voltage
- Ambient temperature of vehicle and charger. Charging times may be longer if the temperature is at the limits of the permitted ambient temperature.
  - ▷ Refer to chapter "Ground monitoring" on page 21.
- Temperature of the high-voltage battery and control unit
- Passenger compartment precooling/heating activated
- Current-carrying capacity of the power plug and vehicle plug
- Operating further large-scale consumers. In the event of a weak installation design, the charging current may be reduced by the overload protection of the energy manager.











### Information

Due to different national mains supply systems, various cable versions are available. This may result in the full charging power not being available. Further information is available from your qualified specialist workshop. Porsche recommends a Porsche partner as they have trained workshop personnel and the necessary parts and tools.

## Starting, pausing and ending charging

### Starting charging

- ✓ The charger is ready for operation.
  - ✓ The desired charging current limit is selected.
1. Insert the vehicle plug in the vehicle charge port.

- Connection to the vehicle is established.
  -   The **CHARGE STATUS** button lights up yellow.
  -  The **50 %**, **100 %** or energy manager indicator light lights up green.
- If a connection is established to the vehicle:
  -   **ENERGY MANAGER** indicator light,
  -   **DOMESTIC CONNECTION** indicator light and
  -   **VEHICLE** indicator light flash 1x green.
-   The **CHARGE STATUS** button and **50 %**, **100 %** or energy manager indicator light light up green.

### 2. Charging starts automatically.

- ➔   The **CHARGE STATUS** button pulses green.

If no operation via the charger or the web application occurs, the charger switches to standby mode after 10 minutes. The indicator lights no longer light up.

The vehicle continues to be charged.

### Information

If standby mode is activated in the Web Application of the charger and then there is no further use via the charger or the Web Application, after 10 minutes the charger switches to standby mode. The charger can then no longer be accessed via the Web Application.

Activation of standby mode serves to save power. The function can be disabled in the Web Application of the charger.

## Pausing charging

### Information



- Charging is controlled by the vehicle. Charging can only be terminated at the vehicle or via the charger in the event of a malfunction.
- In the case of high charger temperatures, the charging power is reduced. If necessary, an over-temperature cut-off interrupts charging to prevent overheating.

▷ Refer to chapter "Malfunctions" on page 25.

Charging is controlled by the vehicle and may occasionally be paused, e.g. to optimise power consumption.

The vehicle starts charging again automatically. Charging can be stopped on the vehicle.

## Stopping charging

- ✓ Charging was completed successfully.
  - ▶ Disconnect the vehicle plug from the vehicle charge port.
    - ➔   The **CHARGE STATUS** button lights up white.
- The vehicle is no longer connected.

## Charging current limiting

The maximum available charging current is determined by the types of cable that are connected. The charger detects the voltage and the available current automatically.

The charging current can also be reduced by other consumers in the home network, e.g. by an electric heater or water heater. If you are unsure about this, contact a qualified electrician.

To prevent overheating of the electrical installation with household cables, the charging current is limited at delivery to 50 % when using household electrical sockets.

You can manually set the charging power to be used for charging with the **CHARGE STATUS** button. The last charging current set is saved. If the charger is connected to the energy manager, this can assume the control function.

### Ground monitoring

**⚠ DANGER**

Electric shock, short circuit, fire, explosion

Use of the charger without active ground monitoring can cause electric shocks, short circuits, fire, explosions or burns.

- ▶ The charger should preferably be operated in earthed mains supply systems.
- ▶ Only deactivate ground monitoring in non-earthed mains supply systems.
- ▶ Activate ground monitoring in earthed mains supply systems.

### Deactivating ground monitoring

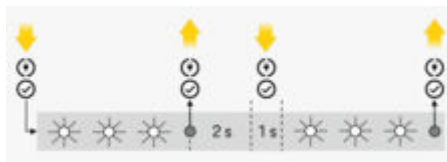

Fig. 17: Key sequence for deactivating ground monitoring

- ✓ The **CHARGE STATUS** button lights up red.
  - ✓ The **DOMESTIC** indicator light and the **VEHICLE** indicator light light up red.
  - ✓ Ground monitoring has interrupted the charging process or prevents it from starting.
1. Press and hold the **CHARGE STATUS** and **MULTI-FUNCTION BUTTON** simultaneously.
    - ➔ The **CHARGER** indicator light flashes white when you do so.
  2. As soon as the **CHARGER** indicator light stops flashing, release both buttons.
  3. After 2 seconds (count the time as soon as the flashing stops), press and hold both buttons again simultaneously for at least 5 seconds.

Ground monitoring is deactivated when the **DOMESTIC CONNECTION** indicator light and the **VEHICLE** indicator light light up yellow. During charging, the **CHARGE STATUS** button additionally pulses green.

- ➔ Monitoring remains deactivated for subsequent charging processes.

### **i** Information

For easier operation of the charger, your fingers should cover the buttons completely and apply even pressure.

### Activating ground monitoring

If the charger is operated in an earthed mains supply system, activate **ground monitoring**.

- ▶ Press and hold the **CHARGE STATUS** button and the **MULTI-FUNCTION BUTTON** simultaneously for at least 5 seconds. The **CHARGER** indicator light flashes white when you do so.

Ground monitoring can also be activated via the web application:

▶ For information on the web application, see the instructions at <https://www.porsche.com/international/about-porsche/e-performance/help-and-contact/>

If you require a different language, please select the appropriate website for your country.

## Logging into the web application

### **i** Information

You will find the data for logging into the Web Application in the enclosed letter containing access data. The security field contains the PUK. This field is printed over with a special ink that covers the PUK.

Only after moistening this field under running water does the ink fade, making the PUK visible.

Do not rub or scratch the field while moistening it, as otherwise the PUK could also be damaged.

- ✓ The access data is to hand.

▶ Enter a password.

### **i** Information

After 25 minutes of inactivity, the user is automatically logged out of the Web Application.

## Opening the web application

### Opening the web application of the charger

- ✓ Charger is connected to the PLC network.
  - ▶ Enter the host name of the charger (<Host-name> or <Hostname>/) in the browser's address bar. The host name is in the letter containing access data.
    - or –
    - Enter the IP address of the charger in the browser's address bar. The IP address was assigned by the DHCP server while your device and the charger were pairing and can be viewed in the router settings.
  - ▶ Refer to chapter "Connecting the charger to a PLC network" on page 17.
  - ▶ For information on the web application, see the instructions at <https://www.porsche.com/international/about-porsche/e-performance/help-and-contact/>
- If you require a different language, please select the appropriate website for your country.
- ▶ Refer to chapter "Access data" on page 6.

## Using the web application

### Opening the web application

#### Opening the web application of the charger

- ✓ Device and charger are in the same network via a PLC connection.
- 1. Open your browser.
- 2. Enter the host name of the charger in the browser's address bar. The host name is in the letter containing access data.
  - or –
  - Enter the IP address of the charger in the browser's address bar. The IP address was assigned by the DHCP server while your device and the charger were pairing and can be viewed in the router settings.

#### Redirecting to the web application

##### Information

Depending on which browser you are using, the web application may not open immediately. Instead, a notice regarding the browser's security settings may be displayed first.

1. In the displayed browser warning message, select **Advanced**.
2. In the next dialogue box, add the SSL certificate as an exception.
  - ➔ The SSL certificate is confirmed and the Web Application opens.

## Connections

### Powerline Communication (PLC)

If the charger is connected to a PLC network, network information (e.g. host name, MAC address, IP address) is displayed here.

### Energy manager

For charging control to be assumed by the energy manager, first the charger (EEBus device) and the energy manager must be connected to one another. In open mode, connection with an unknown energy manager is established on the charger itself and in the Web Application of the energy manager.

##### Information

If the charger is in private mode, the connection to the energy manager must also be confirmed in the web application of the charger.

▶ Refer to the section "Adding an EEBus device" in the web application instructions of the Porsche Home Energy Manager.

▶ Refer to the Porsche Mobile Charger Plus operating and installation manual.

#### Viewing the connection to the energy manager in the web application:

- ▶ In the Web Application of the charger, navigate to **Connections** ▶ **Energy manager**.
  - ➔ The connected energy manager is displayed with the status **Energy manager connected**. You can see the device information of the energy manager.



**Open mode**

The charger is configured to open mode upon delivery. The energy manager is therefore detected and connected in the home network automatically. For automatic pairing with the energy manager, the following conditions must be satisfied:

- ✓ **ENERGY MANAGER** charge status has been selected on the charger.
- ✓ The charger and energy manager are located in the same PLC network.
- ✓ The charger has been added as an EEBus device in the Web Application of the energy manager.
- ▶ We recommend switching to private mode after you have operated the charger for the first time.

**Activating private mode**

1. Navigate to **Connections ▶ Energy manager** in the Web Application.
2. Activate **Secure mode**.

**Confirming the connection to the energy manager**

- ✓ The charger and energy manager are in the same network.
  - ✓ Private mode is activated.
  - ✓ The connection to the charger has already been confirmed in the web application of the energy manager.
1. In the Web Application of the charger, navigate to **Connections ▶ Energy manager**.
    - ➔ The energy manager is shown in the **Available energy managers** list.
  2. Select and expand the energy manager.
  3. Select **Pair device**.

4. In the **Establish connection** dialogue box, check the identity of the energy manager once more using the ID number (SKI), then select **Connect**.
  - ➔ The energy manager is successfully connected and the status **Energy manager connected** is displayed.

The energy manager settings (e.g. information on the charging current, overload protection and optimised charging) are adopted by the charger.

**Disconnecting from the energy manager**

In private mode, the connection to the energy manager can be disconnected in the Web Application of the charger.

- ✓ Private mode is activated.
1. In the web application of the charger, navigate to **Connections ▶ Energy manager**.
    - ➔ The connected energy manager is shown in the **Available energy managers** list.
  2. Select **Disconnect**.
    - ➔ The charger is disconnected from the energy manager.

**Settings**

**System**

**Changing the password**

You can change the login password for the Web Application. The new, chosen password overwrites the initial password from the letter containing access data.

- ▶ Select **Change** and enter a new password.

**Entering language and country**

Field	Explanation
Language	Selects the language for the Web Application.
Country	The country of use. The configuration settings vary depending on the country. If you enter a country that is not the actual place of use, some settings may not be available.

**Controlling energy consumption**

Activate standby mode to save electricity.

If standby mode is activated and then there is no further use via the charger or the Web Application, after 10 minutes the charger switches to standby mode. The charger can then no longer be accessed via the Web Application.

- ▶ Activate the **Standby mode** function.
  - The device needs some time to exit standby mode and become ready to use once more.

**i Information**

The charger automatically switches to standby mode after a longer period of inactivity. Press the Power button to start it up again.

## Activating reset to factory settings

If you activate this function, a reset to the factory settings is possible on the charger itself. If you deactivate this function, a reset to the factory settings can only take place in the web application.

- ▶ Activate the **Reset to factory settings** function.
  - ▷ Refer to the "Reset to factory settings" section in the Porsche Mobile Charger Plus operating manual.
  - XXXLINKXXX Refer to the "Resetting to factory settings" section on page 6.

## Charging

### Mains status

The charger automatically detects the information on the mains status shown here.

Display	Explanation
<b>Mains phases</b>	Number of phases in the supply cable.
<b>Cable type</b>	Type of vehicle charging cable. The cable type provides important information for setting the maximum charging current.
<b>Derating reason</b>	The number <b>0</b> indicates that the charging power is not restricted.  A number <b>&gt; 0</b> indicates that the charging power is restricted due to overheating.

## Ground monitoring

**⚠ DANGER** Electric shock, short circuit, fire, explosion

Use of the charger without active ground monitoring can cause electric shocks, short circuits, fire, explosions or burns.

- ▶ The charger should preferably be operated in earthed mains supply systems.
- ▶ Only deactivate ground monitoring in non-earthed mains supply systems.
- ▶ Activate ground monitoring in earthed mains supply systems.

Ground monitoring can be activated in the web application or on the charger. For safety reasons, it can only be deactivated on the charger.

- ▶ Select the **Activate ground monitoring** function.
  - ▷ To activate and deactivate ground monitoring on the charger, refer to the Porsche Mobile Charger Plus operating and installation manual.

## Setting the electric current and energy manager

Here, you can manually set the charging power to be used:

- **Reduced power:** The charger charges at 50 % of the maximum charging current.
- **Full power:** The charger charges at 100 % of the maximum charging current.
- **Energy manager:** If the charger is connected to the energy manager, the overload protection monitors the charging current to the charger.
- ▶ Select the desired function.

## Service

### Displaying device information

This information is based on the charger data, e.g. the version number, serial number and host name.

Your Porsche service partner will need this data in the event of an error message.

### Displaying diagnosis

Shows the diagnostic parameters, with information on the device temperature.

- ▶ Select whether the temperature should be given in degrees **Celsius** or **Fahrenheit**.

### Displaying event memory information

The event memory information shown here relates to error messages that occurred during the system test. The active and the passive event memories are displayed. Unlike passive events, active events or errors are currently still persisting.

- ▶ Expand the section to view the event memory.

### Resetting to factory settings

If you activate this function, all personal data and configurations, e.g. charging history and network settings, are deleted. Moreover, all passwords will be reset to the initial passwords indicated in the letter containing your access data.

- ▶ Activate the **Reset to factory settings** function.

## Malfunctions

The charger indicates faults and malfunctions by red or yellow indicator lights coming on or flashing.















### NOTICE

Damage to the charger













- ▶ If a fault persists or recurs, disconnect the charger from the mains supply and contact a qualified electrician. Porsche recommends a Porsche partner as they have trained workshop personnel and the necessary parts and tools.













- ▶ Refer to chapter "Control unit" on page 9.

The following overview contains recommendations for dealing with malfunctions.















Indicator lights	Meaning	Remedy
<ul style="list-style-type: none"> <li>●  The <b>CHARGE STATUS</b> button lights up red.</li> <li>●  The <b>DOMESTIC CONNECTION</b> indicator light lights up red.</li> <li>●  The <b>VEHICLE</b> indicator light lights up red.</li> <li>●  The <b>CHARGER</b> indicator light lights up red.</li> <li>●  The <b>MULTI-FUNCTION BUTTON</b> lights up red.</li> </ul>	<p>Watchdog error or load relay permanently connected</p>	<ul style="list-style-type: none"> <li>▶ Disconnect and reconnect the power plug.</li> <li>▶ If this does not remedy the fault, have the domestic installation checked by a qualified electrician.</li> </ul>
<ul style="list-style-type: none"> <li>●  The <b>CHARGE STATUS</b> button lights up red.</li> <li>●  The <b>DOMESTIC CONNECTION</b> indicator light lights up red.</li> <li>●  The <b>VEHICLE</b> indicator light lights up red.</li> <li>●  The <b>CHARGER</b> indicator light lights up red.</li> <li>●  The <b>MULTI-FUNCTION BUTTON</b> flashes red.</li> </ul>	<p>Residual current device - triggering/residual current</p>	<ul style="list-style-type: none"> <li>▶ Reset the fault by pressing and holding the multi-function button (for at least 2 seconds).</li> <li>▶ If this does not remedy the fault, have the domestic installation checked by a qualified electrician.</li> </ul>
<ul style="list-style-type: none"> <li>●  The <b>CHARGE STATUS</b> button lights up red.</li> <li>●  The <b>DOMESTIC CONNECTION</b> indicator light lights up red.</li> <li>●  The <b>VEHICLE</b> indicator light lights up red.</li> <li>●  The <b>CHARGER</b> indicator light lights up red.</li> </ul>	<p>Multi-function button LED defective</p>	<ul style="list-style-type: none"> <li>▶ Disconnect and reconnect the power plug.</li> <li>▶ If this does not remedy the fault, have the domestic installation checked by a qualified electrician.</li> </ul>

## Malfunctions

Indicator lights	Meaning	Remedy
<ul style="list-style-type: none"> <li> The <b>CHARGE STATUS</b> button lights up red.</li> <li> The <b>DOMESTIC CONNECTION</b> indicator light flashes red.</li> <li> The <b>VEHICLE</b> indicator light flashes red.</li> <li> The <b>CHARGER</b> indicator light flashes red.</li> </ul>	Wiring fault	<ul style="list-style-type: none"> <li>▶ Disconnect and reconnect the power plug.</li> <li>▶ If this does not remedy the fault, have the domestic installation checked by a qualified electrician.</li> </ul>
<ul style="list-style-type: none"> <li> The <b>DOMESTIC CONNECTION</b> indicator light lights up red.</li> <li> The <b>VEHICLE</b> indicator light lights up red.</li> <li> The <b>CHARGER</b> indicator light lights up red.</li> <li> The <b>MULTI-FUNCTION BUTTON</b> lights up red.</li> </ul>	Power LED faulty	<ul style="list-style-type: none"> <li>▶ Disconnect and reconnect the power plug.</li> <li>▶ If this does not remedy the fault, have the domestic installation checked by a qualified electrician.</li> </ul>
<ul style="list-style-type: none"> <li> The <b>CHARGE STATUS</b> button lights up red.</li> <li> The <b>DOMESTIC CONNECTION</b> indicator light lights up red.</li> <li> The <b>VEHICLE</b> indicator light lights up red.</li> </ul>	The protective conductor is interrupted/not present	<ul style="list-style-type: none"> <li>▶ Disconnect and reconnect the power plug.</li> <li>▶ Only <b>non-earthed</b> mains supply systems (e.g. IT networks): If necessary, charge the vehicle with protective conductor monitoring deactivated. <ul style="list-style-type: none"> <li>▶ Refer to chapter "Ground monitoring" on page 21.</li> </ul> </li> <li>▶ Only <b>earthed</b> mains supply systems: Have the control unit checked by a qualified specialist workshop/Porsche partner. Have the mains supply/domestic connection checked by a qualified electrician.</li> </ul>
<ul style="list-style-type: none"> <li> The <b>CHARGE STATUS</b> button lights up red.</li> <li> The <b>DOMESTIC CONNECTION</b> indicator light flashes red.</li> </ul>	Overvoltage	<ul style="list-style-type: none"> <li>▶ Disconnect and reconnect the power plug.</li> <li>▶ If this does not remedy the fault, have the domestic installation checked by a qualified electrician.</li> </ul>

Indicator lights	Meaning	Remedy
<ul style="list-style-type: none"> <li> The <b>CHARGE STATUS</b> button lights up red.</li> <li> The <b>VEHICLE</b> indicator light lights up red.</li> </ul>	Overload	<ul style="list-style-type: none"> <li>▶ Disconnect and reconnect the power plug.</li> <li>▶ If this does not remedy the fault, have the domestic installation checked by a qualified electrician.</li> </ul>
<ul style="list-style-type: none"> <li> The <b>CHARGE STATUS</b> button lights up red.</li> <li> The <b>CHARGER</b> indicator light lights up red.</li> </ul>	Relay fault	<ul style="list-style-type: none"> <li>▶ Disconnect and reconnect the power plug.</li> <li>▶ If this does not remedy the fault, have the domestic installation checked by a qualified electrician.</li> </ul>
<ul style="list-style-type: none"> <li> The <b>CHARGE STATUS</b> button lights up red.</li> <li> The <b>CHARGER</b> indicator light flashes red.</li> </ul>	Self-test failed	<ul style="list-style-type: none"> <li>▶ Disconnect and reconnect the power plug.</li> <li>▶ If this does not remedy the fault, have the domestic installation checked by a qualified electrician.</li> </ul>
<ul style="list-style-type: none"> <li> The <b>CHARGE STATUS</b> button pulses red.</li> <li> The <b>CHARGER</b> indicator light lights up red.</li> </ul>	Load cycle error	<ul style="list-style-type: none"> <li>▶ The charger is defective and must not be operated. Visit a qualified specialist workshop/Porsche partner.</li> </ul>
<ul style="list-style-type: none"> <li> The <b>CHARGE STATUS</b> button in accordance with the charge status.</li> <li> The <b>ENERGY MANAGER</b> indicator light lights up red.</li> <li> The <b>50%</b> indicator light lights up green.</li> </ul>	PLC or energy manager connection error	<ul style="list-style-type: none"> <li>▶ During initial operation, restart the charger and repeat start-up. Check the connection to the PLC network. Check the connection to the energy manager.</li> </ul>
<ul style="list-style-type: none"> <li> The <b>CHARGE STATUS</b> button lights up red.</li> <li> The <b>DOMESTIC CONNECTION</b> indicator light lights up yellow.</li> </ul>	Infrastructure plug overtemperature	<ul style="list-style-type: none"> <li>▶ The device has switched off due to overtemperature. Wait until the normal temperature is reached again. If necessary, protect the charger from direct sunlight.</li> </ul>

## Malfunctions

Indicator lights	Meaning	Remedy
<ul style="list-style-type: none"> <li> The <b>CHARGE STATUS</b> button lights up red.</li> <li> The <b>DOMESTIC CONNECTION</b> indicator light flashes yellow.</li> </ul>	Undervoltage/invalid mains frequency	<ul style="list-style-type: none"> <li>▶ The charging process was interrupted. Wait. Do not take any action.</li> </ul>
<ul style="list-style-type: none"> <li> The <b>CHARGE STATUS</b> button lights up red.</li> <li> The <b>VEHICLE</b> indicator light flashes yellow.</li> </ul>	Invalid CP signal	<ul style="list-style-type: none"> <li>▶ Disconnect and reconnect the power plug.</li> </ul>
<ul style="list-style-type: none"> <li> The <b>CHARGE STATUS</b> button lights up red.</li> <li> The <b>CHARGER</b> indicator light lights up yellow.</li> </ul>	Overtemperature	<ul style="list-style-type: none"> <li>▶ The charger has switched off due to overtemperature. Wait. If necessary, protect the charger from direct sunlight.</li> </ul>
<ul style="list-style-type: none"> <li> The <b>CHARGE STATUS</b> button lights up red.</li> <li> The <b>CHARGER</b> indicator light flashes yellow.</li> </ul>	Infrastructure or vehicle cable cannot be read	<ul style="list-style-type: none"> <li>▶ Disconnect and reconnect the power plug.</li> </ul>
<ul style="list-style-type: none"> <li> The <b>CHARGE STATUS</b> button pulses green.</li> <li> The <b>DOMESTIC CONNECTION</b> indicator light lights up yellow.</li> </ul>	Infrastructure plug overtemperature/only one phase of multi-phase socket connected	<ul style="list-style-type: none"> <li>▶ The charging power of the charger is reduced due to high temperature. Wait. If necessary, protect the charger from direct sunlight.</li> <li>▶ A multi-phase socket may only have one phase connected. In this case, have a qualified electrician check whether the socket is correctly connected to the mains supply.</li> </ul>
<ul style="list-style-type: none"> <li> The <b>CHARGE STATUS</b> button pulses green.</li> <li> The <b>CHARGER</b> indicator light lights up yellow.</li> </ul>	Derating	<ul style="list-style-type: none"> <li>▶ The charger has reduced the charging power due to high temperature. Wait. If necessary, protect the charger from direct sunlight.</li> </ul>
<ul style="list-style-type: none"> <li> ON/OFF pulses green.</li> <li> Power supply/domestic connection lights up yellow.</li> <li> Vehicle lights up yellow.</li> </ul>	The vehicle is being charged with protective conductor monitoring deactivated.	<ul style="list-style-type: none"> <li>▶ The vehicle should ideally be charged with protective conductor monitoring activated. <ul style="list-style-type: none"> <li>▶ Refer to chapter "Ground monitoring" on page 21.</li> </ul> </li> </ul>

Indicator lights	Meaning	Remedy
The charger has switched off completely.		<ul style="list-style-type: none"><li>▶ The charger is in standby mode or has switched off due to a fault.</li><li>▶ Check whether the charger is in standby mode by touching the charging current limiting button.</li></ul>

### Transport



**WARNING**

Unsecured load

An unsecured, incorrectly secured or incorrectly positioned charger can slip out of place and endanger the vehicle occupants during braking, acceleration, direction changes or in accidents.

- ▶ Never transport the charger unsecured.
- ▶ Always transport the charger in the luggage compartment, never in the passenger compartment (e.g. on or in front of the seats).

### Securing the Charger for Transport

The charger is supplied with or without a transport case, depending on vehicle type.

- ▶ If a transport case is supplied: Always stow and transport the charger in the case. Attach the transport case to the front and rear tie-down rings with hooks.

For information on the tie-down rings in the luggage compartment:

- ▶ Refer to the Driver's Manual.
- ▶ If a transport case is not supplied: Stow the charger in the rear luggage compartment for transport.
- ▶ Depending on vehicle type, stow the charger in such a way that it does not endanger any occupants in dangerous situations.

### Cleaning and maintenance

Check the charger regularly for damage and soiling and clean if necessary.



**DANGER**

Electric shock, fire

Risk of serious or fatal injury due to fire or electric shock.

- ▶ Never immerse the charger or plugs in water or spray them directly with water (e.g. high-pressure cleaning equipment or garden hoses).
- ▶ Only clean the charger when the control unit has been fully disconnected from the mains supply and from the vehicle. Use a dry cloth for cleaning.

### Disposal

#### Electric/electronic devices and used batteries



Electrical/electronic devices and batteries can be deposited at a collection point or waste management facility.

Electric and electronic devices that are labelled with the crossed-out waste bin symbol as well as used batteries must not be thrown away with the domestic waste, but rather must be disposed of properly.

- ▶ Observe country-specific disposal regulations.
- ▶ Hand in old batteries and electric and electronic devices at a collection point.
- ▶ The 12-volt lithium battery is hazardous goods. Do not tamper with this battery and never dispose of it yourself.

For further information on proper disposal:

- ▶ Contact your Porsche partner.

### Driver's Manual



Observe disposal instructions in accordance with the marking.



## Technical Data

<b>Electrical data</b>	<b>PMCP11 x<sup>1</sup></b>
Power	<b>11 kW / 7.2 kW</b>
Rated current	16 A, 3-phase 32 A, 1-phase
Mains voltage	100 – 240/400 V
Mains frequency	50 Hz/60 Hz
Overvoltage category (IEC 60664)	II
Integrated residual current device	Type A (AC: 30 mA) + DC: 6 mA
Protection class	I
Degree of protection	IP55
Vehicle plug	Type 2
<b>Mechanical data</b>	<b>PMCP11 x<sup>1</sup></b>
Weight of control panel with cable	4.0 kg
Length of vehicle cable	4.5 m
Length of supply cable	0.9 m or 1.6 m

1. The "x" stands for pending design changes and can be any letter.

Ambient and storage conditions	PMCP11 x <sup>1</sup>
Ambient temperature	-30°C to +50°C
Humidity	5% – 95% non-condensing
Altitude	max. 5,000 m above sea level

## Identification plate

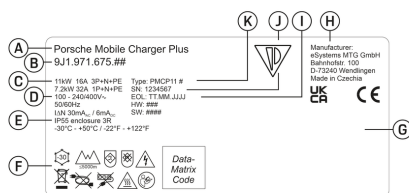

Fig. 18: Identification plate (example)

- A** Product name
- B** Product number
- C** Power and rated current
- D** Mains voltage
- E** Degree of protection
- F** Pictograms for operation
- G** Certification details
- H** Manufacturer
- I** Date of manufacture
- J** Serial number
- K** Type designation

## Production information

### Date of manufacture

The date of manufacture of the charger can be found on the identification plate after the abbreviation “EOL”.

It is shown in the following format: Day of production.Month of production.Year of production

### Charger manufacturer

eSystems MTG GmbH  
Bahnhofstrasse 100  
73240 Wendlingen  
Germany

### Electrical testing

In the event of questions on regular electrical testing of the charging infrastructure (e.g. VDE 0702), please refer to <https://www.porsche.com/international/accessoriesandservice/porscheservice/vehicleinformation/documents/> or contact a Porsche partner.

### Declaration of conformity

The charger has a radio system.

The manufacturer of these radio systems declares that these radio systems comply with the specifications for their use in accordance with Directive 2014/53/EU.

The full text of the EU Declaration of Conformity is available at the following internet address:

► <http://www.porsche.com/international/accessoriesandservice/porscheservice/vehicleinformation/documents>

## Brazil



03725-21-12707

Este equipamento opera em caráter secundário, isto é, não tem direito a proteção contra interferência prejudicial, mesmo de estações do mesmo tipo, e não pode causar interferência a sistemas operando em caráter primário”. Para maiores informações, consulte o site da ANATEL [www.anatel.gov.br](http://www.anatel.gov.br)

1. The “x” stands for pending design changes and can be any letter.



## Importers

### **Vereinigte Arabische Emirate**

#### **Abu Dhabi: Ali & Sons Co. L.L.C**

Porsche Centre Abu Dhabi

Zayed 2nd Street

Abu Dhabi

United Arab Emirates

P.O. Box 915

Telefon: +971 2 619 3911

#### **Dubai: Al Nabooda Automobiles L.L.C**

Porsche Centre Dubai

Sheikh Zayed Road E11

Dubai

United Arab Emirates

P.O. Box 10773

Telefon: +971 4 305 8555

### **Great Britain**

Porsche Cars Great Britain Ltd.

Bath Road

Calcot, Reading, Berkshire

RG31 7SE

United Kingdom

### **Colombia**

Autoelite S.A.S

Av. Carrera 70

No. 99-15, Bogotá

### **México**

Volkswagen de México S.A. de C.V.

Autopista México Puebla km 116

San Lorenzo Almecatla, Cuautlancingo

72700 Puebla

Telefon: +52 222 230 9971

### **Russia**

Porsche Russland

Ленинградское шоссе дом 71А, строение 10

125445, Москва, Россия

Telefon: +7-495-580-9911

### **Singapore**

Porsche Asia Pacific Pte Ltd

20 McCallum Street #12-01

Tokio Marine Centre

Singapore 069046

## Index

**A**

Access data.....	6
Serial number of the charger.....	6
Web application.....	6
Activating and deactivating standby mode.....	23
Activating open mode.....	22
Activating private mode.....	22
Ambient and storage conditions.....	31

**B**

Browser requirements.....	18
Button	
Charge status.....	9
Multi-function.....	9

**C**

Changing the login password.....	23
Changing the password.....	23
Charge status.....	18
Charge status button.....	9
Charger	
Activating open mode.....	22
Activating private mode.....	22
Pairing with the energy manager.....	22
Charging	
Charging current limit.....	20
Charging the vehicle.....	20
Setting charging current limiting.....	20
Starting.....	20
Vehicle charge port.....	19
Warnings.....	19
Charging current limiting.....	20
Charging history.....	18
Charging process	
Energy consumption.....	18
View.....	18
Charging times.....	19

Cleaning.....	30
Configuring an IP address.....	22
Connecting a charger	
To the energy manager.....	17
To the PLC network.....	17
Connection	
Ensuring quality of PLC network.....	17
Establishing to the charger.....	16, 18
Reconnecting.....	18

Connections	
Energy manager.....	16
Hotspot.....	18
Control unit.....	9
Attaching to the wall mount.....	11
Overview of connections.....	9
Current charging process.....	18

**D**

Date of manufacture.....	32
Declaration of conformity.....	32
Device status.....	18
Device temperature.....	24
Device temperature diagnosis.....	24
Displaying cable type.....	24
Displaying charging power.....	18
Displaying device information.....	24
Displaying mains phases.....	24
Displaying mains status.....	24
Disposal.....	30

**E**

Electrical data.....	31
Energy consumption	
Charging process.....	18
Controlling.....	23
Energy manager.....	16
Adapting the charging current.....	16
Adding.....	16

Displaying.....	22
Pairing.....	22
Entering a country.....	23
Entering a language.....	23
Error message.....	24
Event memory.....	24

**F**

Factory settings.....	6
Factory settings, activating reset.....	24
Factory settings, resetting to.....	24
Fault display.....	25
Fault indication.....	25
For the Driver's Manual	
Further Information.....	3
Further Information.....	3

**G**

Ground monitoring.....	24
Activating.....	21
Deactivating.....	21

**H**

Home network	
Host name.....	22
IP address.....	22
Host name.....	22
Hotspot.....	18
Household electrical outlet, supply cables.....	12

**I**

Identification plate.....	32
Importers.....	33
Indicator lights.....	25
Industrial electrical outlet, supply cables.....	12
Initial operation.....	15, 18
Initial password.....	6

Installing the basic wall mount.....	10
Installing the connector fastener.....	10
<b>L</b>	
Logging into the web application.....	21
Lost access data.....	6
<b>M</b>	
Maintenance.....	30
Malfunctions.....	25
Manufacturer.....	32
Mechanical data.....	31
Multi-function button.....	9
<b>O</b>	
Opening the web application.....	22
Operating instructions.....	19
Operating mode	
Direct connection via PLC.....	8
In the same PLC network.....	8
Standalone.....	7
Via the web application.....	7
Overview of pictograms.....	3
<b>P</b>	
Pictograms, overview.....	3
PLC network, ensuring good connection quality... ..	17
Possible uses of the charger.....	7
Production information.....	32
Proper use.....	5
PUK	
Changing the password.....	6
Loss.....	6
<b>R</b>	
Required tools.....	10
Resetting to factory settings.....	24
<b>S</b>	
Safety instructions.....	4
Scope of delivery.....	5
Securing during transport.....	30
Selecting charge status.....	15
Selecting the installation location.....	9
Serial number of the charger.....	6
Service.....	24
Standalone operation.....	7
Standby mode.....	23
Supply cable	
Changing.....	14
Disconnecting.....	15
Housing socket.....	12
Industrial socket.....	12
Securing.....	15
Selecting.....	11
Symbols in this Owner's Manual.....	1
System test.....	24
<b>T</b>	
Technical Data.....	31
Tools.....	10
Transport, securing charger.....	30
<b>V</b>	
Vehicle charge port.....	19
Vehicle charging cable, plug.....	11
<b>W</b>	
Warning notices setup.....	1
Web application	
Changing the password.....	6
Initial operation.....	18
Initial password.....	6
Logging in.....	21
Lost password.....	6
Opening.....	22
Resetting to factory settings.....	6