



Porsche Mobile Charger

Good to know – Owner's Manual

06/2023

Porsche, the Porsche Crest, Panamera, Cayenne and Taycan are registered trademarks of Dr. Ing. h.c. F. Porsche AG.

Printed in Germany.

Reprinting, even of excerpts, or duplication of any type is only permissible with the written authorization of Dr. Ing. h.c. F. Porsche AG.

© Dr. Ing. h.c. F. Porsche AG

Porscheplatz 1

70435 Stuttgart

Germany

Operating instructions

Keep these operating instructions and hand them over to the new owner when you sell your charger.

Due to different requirements in various countries, the information in the thumb index tabs of this manual will be different. To ensure that you are reading the thumb index tab that applies to your country, compare the article number of the charger shown in the "Technical Data" section with the article number on the identification plate on the charger.

Suggestions

Do you have any questions, suggestions or ideas regarding your vehicle or these instructions?

Please write to us:

Dr. Ing. h.c. F. Porsche AG

Vertrieb Customer Relations

Porscheplatz 1

70435 Stuttgart

Germany

Equipment

Because Porsche vehicles undergo continuous development, equipment and specifications may not be as illustrated or described in this manual. Items of equipment are sometimes optional or vary depending on the country in which the vehicle is sold.

For information on retrofitting options, please contact an authorized Porsche dealer. Porsche recommends an authorized Porsche dealer as they have trained technicians and the necessary parts and tools.

Owing to the different legal requirements in individual countries, the equipment in your vehicle may vary from that described in this Owner's Manual. If your Porsche is fitted with any equipment not described in this manual, your authorized Porsche dealer will be glad to provide information regarding correct operation and care of the items concerned.

About this Owner's Manual

Warning notes and symbols

Different types of warning notes and symbols are used in this Owner's Manual.



DANGER

Serious injury or death

Failure to observe warning notes in the "Danger" category will result in serious injury or death.



WARNING

Possible serious injury or death

Failure to observe warning notes in the "Warning" category may result in serious injury or death.



CAUTION

Possible moderate or slight injury

Failure to observe warning notes in the "Caution" category may result in moderate or slight injury.

NOTE

Vehicle damage possible

Failure to observe warning notes in the "Notice" category can result in damage to the vehicle.



Information

Additional information is provided under "Information".

- ✓ Prerequisites that must be fulfilled in order to use a function.
- ▶ Instructions that must be followed.

1. Instructions are numbered in cases where a sequence of steps must be followed.

2. Instructions that must be followed on the center display.

▶ Indicates where you can find more information on a topic.

More Information

You can access the comprehensive Owner's Manual at the following web address:

<https://tinyurl.com/porsche-e-help>



Table of Contents

To the Operating instructions

Pictogram Explanation..... 3

Safety

Safety instructions..... 4

Intended Use..... 6

Includes..... 6

Overview

Charger control unit..... 6

Requirements and prerequisites

Selecting the installation location..... 7

Required tools..... 7

Mounting

Installing the wall bracket..... 7

Set up

Vehicle charging and supply cables..... 9

Operating

Operating instructions..... 13

Charging..... 14

Operating unit status indicators and error messages..... 16

Transport..... 21

Cleaning and maintenance..... 21

Disposal of the product..... 21

Technical data

Type plate..... 24

Production information..... 24

Index..... 25

To the Operating instructions

Pictogram Explanation

Depending on the country, various pictograms may be depicted on the charger.



The charger may only be used when the temperature lies between $-30\text{ }^{\circ}\text{C}$ and $+50\text{ }^{\circ}\text{C}$.



Operate the charger at an altitude no higher than 4,000 m above sea level.



The charger is equipped with a non-switched protective ground conductor.



The charger is equipped with a switched protective ground conductor.



Properly dispose of the charger in compliance with all applicable waste disposal regulations.



Do not use extension cables or cable reels.



Do not use any (travel) adapters.



Do not use multiple electrical sockets.



Do not use a charger with damaged electronics or connecting lines.



There is a risk of electric shock due to incorrect use.



Observe the associated Owner's Manual, particularly the warning and safety instructions.



The surface of the charger can become very hot.



Do not operate the charger in ungrounded power grids (e. g., IT networks). Only operate the charger in grounded power grids.



Designates the type 1 connector with a voltage range $\leq 250\text{ VAC}$.



Designates the type 2 connector with a voltage range $\leq 480\text{ VAC}$.

Safety

Safety instructions

⚠ DANGER

Electric shock, short circuit, fire, explosion

Use of a damaged or incorrect charging cable and a damaged or incorrect electrical socket, improper use of the charger or failure to observe the safety instructions can cause short circuits, electric shocks, explosions, fires or burns.

- ▶ Do not use a damaged and/or soiled charger. Check the cable and plug connection for damage and soiling before use.
- ▶ Only connect the charger to properly installed and undamaged electrical sockets and fault-free electrical installations.
- ▶ Do not use extension cables, cable reels, multiple sockets or (travel) adapters.
- ▶ Disconnect the charger from the power grid during thunderstorms.
- ▶ Do not modify or repair any of the electrical components.
- ▶ **Never** immerse the charger or plugs in water or spray them directly with water (e.g. high-pressure cleaning equipment or garden hoses).
- ▶ Only clean the charger when the control unit has been fully disconnected from the power grid and from the vehicle. Use a dry cloth for cleaning.

⚠ DANGER

Electric shock, fire

Incorrectly installed electrical sockets can cause electric shock or fire when the high-voltage battery is charged using the vehicle charge port.

- ▶ Installation and initial operation of the electrical socket for the charger may only be carried out by a qualified electrician. The qualified electrician is fully responsible for compliance with the relevant standards and regulations.
- ▶ The cross-section of the supply cable for the electrical socket is defined in accordance with the wire length and the locally applicable regulations and standards.
- ▶ Connect the electrical socket used for charging via a separately fused electric circuit, which complies with local laws and standards.
- ▶ The charger is designed for use in the private and semi-public sector (e.g. private property, company parking lots). In some countries, e.g. in Italy and New Zealand, mode 2 charging is **prohibited** in public areas.

Further information is available from your authorized Porsche dealer or your local electricity supplier.

- ▶ Unauthorized persons (e.g. playing children) must not have access to the charger or the vehicle during unsupervised charging.
- ▶ Please read the safety instructions in the installation instructions and the Owner's Manual.

⚠ DANGER

Electric shock, fire

Incorrect handling of the plug contacts can lead to electric shock or fire.

- ▶ Do not touch the contacts on the vehicle charge port and charger.
- ▶ Do not insert any objects into the vehicle charge port or charger.
- ▶ Protect electrical sockets and plug connections against moisture, water and other liquids.

⚠ WARNING

Flammable or explosive vapors

Components of the charger can cause sparks and ignite flammable or explosive vapors.

- ▶ To reduce the risk of explosion, –particularly in garages–, make sure that the control unit is located at least 19.7 in. (50 cm) above the floor during charging.
- ▶ Do not install the charger in potentially explosive areas.



NOTE

This equipment has been tested and found to comply with the limits for a Class B digital device, pursuant to Part 15 of the FCC Rules.

These limits are designed to provide reasonable protection against harmful interference in a residential installation. This equipment generates, uses and can radiate radio frequency energy and, if not installed and used in accordance with the instructions, may

cause harmful interference to radio communications. However, there is no guarantee that interference will not occur in a particular installation. If the wall-charger does cause harmful interference to radio or television reception, which can be determined by turning the equipment off and on, the user is encouraged to try to correct the interference by one or more of the following measures:

- Reorient or relocate the receiving radio or television antenna.
- Increase the separation between the equipment and receiver.
- Connect the equipment into an outlet on a circuit different from that to which the receiver is connected.
- Consult the dealer or an experienced radio/TV technician for help.

Changes or modifications not expressly approved by the manufacturer could void the user's authority to operate the equipment under FCC rules. To comply with FCC RF exposure compliance requirements, the device must be installed to provide a separation distance of at least 20 cm from all persons.

NOTE

Ce dispositif a été testé et déclaré conforme aux limites des appareils numériques de la classe B, selon la section 15 des règlements de la Commission fédérale des télécommunications américaine (FCC).

Ces limites sont conçues pour assurer une protection raisonnable contre un brouillage préjudiciable lorsque l'appareil est utilisé dans un milieu résidentiel. Ce dispositif génère, utilise et peut diffuser de l'énergie sur les fréquences radio et, s'il n'est pas installé et employé conformément aux directives, il peut brouiller les communications radio. Toutefois, rien ne ga-

rantit que des brouillages ne surviendront pas pour des installations particulières. Si ce dispositif brouille les signaux radio ou de télévision, ce qui peut être déterminé en éteignant et en rallumant le dispositif, l'utilisateur devrait tenter de corriger le brouillage par un ou plusieurs des moyens suivants:

- Réorienter ou relocaliser l'antenne de réception.
- Éloigner le dispositif du récepteur.
- Brancher le dispositif dans une prise dont le circuit diffère de celui qui alimente le récepteur.
- Consulter le concessionnaire ou un technicien qualifié dans le domaine de l'audiovisuel pour obtenir de l'aide.

Conformément aux règlements de la Commission fédérale des télécommunications américaine (FCC), toute changement ou modification non expressément approuvée par le fabricant peut annuler l'autorisation accordée à l'utilisateur de faire usage de l'équipement. Le présent appareil est conforme aux CNR d'Industrie Canada applicables aux appareils radio exempts de licence. L'exploitation est autorisée aux deux conditions suivantes : (1) l'appareil ne doit pas produire de brouillage, et (2) l'utilisateur de l'appareil doit accepter tout brouillage radioélectrique subi, même si le brouillage est susceptible d'en compromettre le fonctionnement. Cet appareil numérique de la classe B est conforme à la norme NMB-003 du Canada. Déclaration d'exposition aux radiations: Cet équipement est conforme aux limites d'exposition aux rayonnements IC établies pour un environnement non contrôlé. Cet équipement doit être installé et utilisé avec un minimum de 20 cm de distance entre la source de rayonnement et votre corps.

To ensure uninterrupted charging with the charger, consider the following instructions and recommendations:

- Before installation, check whether the additionally required power for charging a vehicle can be provided sustainably with the present home installation. Secure the home installation with an energy management system if necessary.
- Only operate the charger in grounded power grids. The protective conductor must be installed correctly.
- When installing the electrical socket, select an industrial socket with the highest available power (suited to the electrical home installation) and have it installed by a qualified electrician.
- To the extent technically possible and legally permissible, configure the electrical installation so that the maximum rated power of the electrical socket used is permanently available for charging the vehicle.
- To make the most of the charger's performance and ensure fast charging, use NEMA electrical sockets with the highest possible rated current or industrial sockets in accordance with IEC 60309.
- When charging the high-voltage battery via the household electrical socket/industrial socket, the electrical installation can be loaded to its maximum power capacity. Porsche recommends having the electrical installations used for charging checked regularly by a qualified electrician. Ask an electrician which test intervals make sense during your installation.
- To prevent overheating of the electrical installation, the charging current for household cables is automatically limited on delivery. Have the

Includes

charger commissioned by a qualified electrician and set the charging current limit suited to the home installation.

► Refer to chapter “Charging Current Limit” on page 14.

Intended Use

Charger with integrated control and protection device for charging mode 2 to charge vehicles with a high-voltage battery that comply with the generally accepted standards and directives governing electric vehicles.

- Depending on the regional power grid, use the appropriate device version.
 - Refer to chapter “Technical data” on page 22.

The charger may only be used as a power cable, operator control unit and vehicle cable combination.

Includes

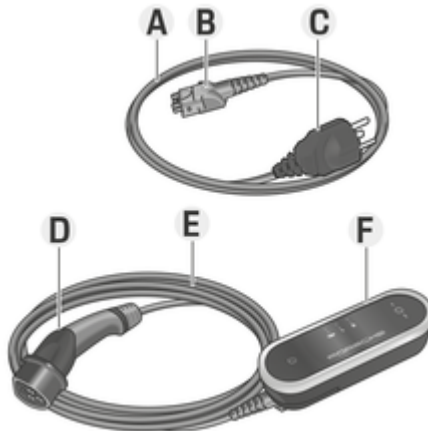

Fig. 1: Charger overview

- A** Power cable (replaceable at operator control unit)
- B** Power cable plug on the operator control unit
- C** Power plug for connection to the power grid
- D** Vehicle charging plug (connector plug for the vehicle)
- E** Vehicle cable (fixed to operator control unit)
- F** Control unit

Overview

Charger control unit

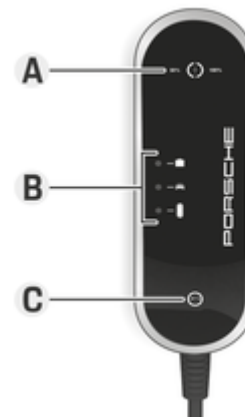

Fig. 2: Control unit

- A** (⏻) On/Off button with light indicator and additional charging current limitation function
- B** 🏠 Power grid/house connection light indicator
🚗 Vehicle light indicator
💡 Control unit light indicator
- C** ⌛ Reset button with light indicator

The operating state of the control unit and the charge limit can be set via the On/Off button (⏻).

The control unit can be reset when a fault current is detected via the reset button (⌛).

The light indicators **A – C** (Fig. 2) display the operating state of the control unit, a set charge limit and possible faults by means of different colors, lights, and flashing.

► Refer to chapter “Operating unit status indicators and error messages” on page 16.

Requirements and prerequisites

Selecting the installation location

⚠ DANGER

Electric shock, fire

Improper use of the charger or non-compliance with the safety instructions can cause short circuits, electric shocks, explosions, fires or burns.

- ▶ Do not install the Basic wall mount in potentially explosive atmospheres.
- ▶ To reduce the risk of explosion, particularly in garages, make sure that the control unit is located at least 19.7 in. (50 cm) above the floor during charging.
- ▶ Observe the locally applicable electrical installation regulations, fire protection measures, accident prevention regulations and escape routes.

The Basic wall mount is designed for indoor and outdoor installation.

The following criteria must be considered when selecting a suitable installation location:

- If possible, install the electrical socket and Basic wall mount in a covered area away from direct sunlight and rain (e.g. in a garage).
- Do not spray the Basic wall mount directly with water (e.g. high-pressure cleaning equipment or garden hoses).
- Do not install the Basic wall mount under hanging objects.

- Do not install the Basic wall mount in stables, livestock buildings or locations where ammonia gases occur.
- Install the Basic wall mount on a smooth surface.
- In order to ensure secure fastening, check the condition of the wall before installation.
- Install the Basic wall mount so that it is not near pathways and the charging cables do not cross any pathways.
- Install the Basic wall mount so that the distance from the power plug to the power socket does not exceed the available supply cable length.
- Install the electrical socket as close as possible to the preferred parking position for the vehicle. Take the orientation of the vehicle into account.
- Make sure the distance of the electrical socket from the floor and ceiling conforms to national standards and regulations, to ensure comfortable use.

► Refer to chapter “Safety instructions” on page 4.

Required tools

- Level
- Drill or hammer drill
- Screwdriver

Mounting

Installing the wall bracket

Mounting standard wall bracket (base)

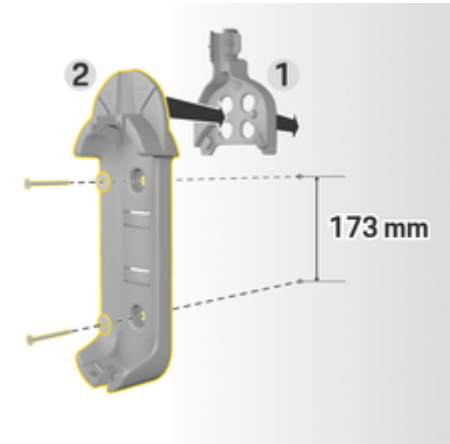

Fig. 3: Drilling dimensions

1. Mark drill holes on the wall.
2. Drill fastening holes and insert anchors.
3. Press standard wall bracket **2** (Fig. 3) into cable guide **1** (Fig. 3) from the front.
4. Screw standard wall bracket onto the wall.

i Information

Install the wall bracket at a height of at least 1 m (3 ft.).

Installing the plug holder

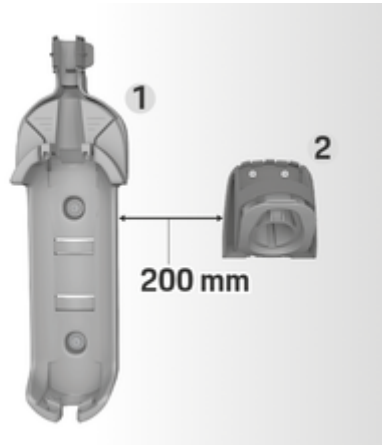

Fig. 4: Distance from wall mount to plug holder

When installing the plug holder, ensure a distance of 7.9 in. (200 mm) from the basic wall mount.

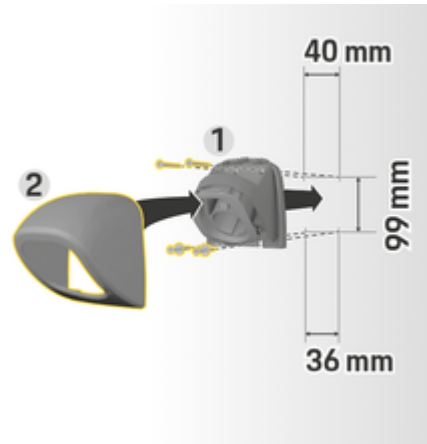

Fig. 5: Drilling dimensions

1. Remove plug holder **1** from the cover (Fig. 5) **2** (Fig. 5).
2. Mark the drill holes on the wall.
3. Drill the mounting holes and insert wall plugs.
4. Screw the plug holder **1** (Fig. 5) to the wall.
5. Fit the cover **2** (Fig. 5) onto the plug holder **1** (Fig. 5) from below and press it upwards.

Inserting the control unit in the wall mount



Fig. 6: Inserting control unit

1. Guide the vehicle cable through the lower opening in the basic wall mount, fit the bottom of the control unit on the locking lug and engage it by pushing it to the rear.
2. Guide the supply cable through the upper opening in the basic wall mount and lock the snap ring by pushing it to the left.
3. Insert the vehicle plug into the plug holder.

Set up

Vehicle charging and supply cables

Vehicle charging cable and connector information

Depending on the country equipment, different vehicle charging connectors **A** and vehicle charging plugs **B** are supplied.



Power cable selection

For regular charging with optimal charging speed, use only the following power cables. The maximum available charging power is up to 9.6 kW (depending on the power grid/home connection and on-board charger).

▸ Refer to chapter “Technical data” on page 22.

Power cable for industrial sockets

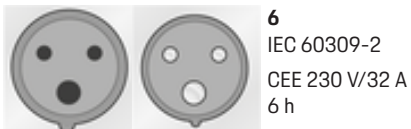
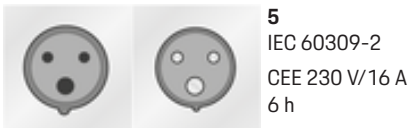

Power cable for household sockets

If an industrial electrical socket is not available, the following power cables can also be used to charge the battery with reduced charging speed.

- ▶ In Canada, each receptacle for the purpose of electric vehicle charging shall be labelled in a conspicuous, legible, and permanent manner, identifying it as an electric vehicle supply equipment receptacle and shall be a single receptacle of CSA configuration 5-20R supplied from a 125 V branch circuit rated not less than 20 A.

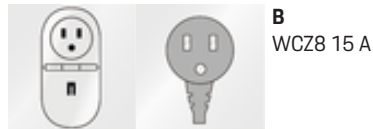

NEMA 6-50/NEMA 14-50 (additional information)

i Information

This recommendation for use applies only to regions with the NEMA 6-50/NEMA 14-50 standard.

Charging your vehicle may result in high electric currents. For safety reasons, it is mandatory to use only components exclusively approved for this purpose and to have the charging equipment installed professionally.

Porsche recommends home owners only install industrial-quality electrical receptacles and have the installation performed by qualified electricians in accordance with the National Electrical Code or applicable local equivalents.

1. for Mexico: 12 A

General safety instructions

Electric shock and fire!

Improper use of the charging equipment and failure to comply with the installation and safety instructions may cause a short circuit, electric shock, explosion, fire or burns.

- ▶ The surface of the charger and associated equipment can become very hot under normal use. This is normal and not an indication of a defect in the charger. Observe the operating instructions provided with the charger, particularly the warnings and safety instructions.
- ▶ Please read the installation instructions in the operating instructions for your charging equipment.
- ▶ Pay particular attention to all the safety and warning instructions provided there.
- ▶ Have the installation carried out by someone with the necessary electrical training and expertise.
- ▶ Pay attention also to the regulations on electrical installations in your country.

Requirements for the power outlet

Unsuitable power outlets

Caution

If the electrical receptacles/outlets are not of sufficient quality, higher temperatures can occur in the receptacle when charging the vehicle using the supplied charging hardware (e.g. Porsche Mobile Charger). This can result in thermal damage to the receptacle and associated wiring. Low quality NEMA receptacle use or improper installation are not an indication of a defect in the vehicle or Porsche charging hardware.

An unsuitable power outlet may cause a short circuit, electric shock, explosion, fire or burns.

- ▶ Use only a power socket type suitable for this installation (see **Suitable power outlet/power plug types**).
- ▶ Only use power outlets that meet the requirements for the quality of the contact areas and clamping (see **Requirements for the quality of the power outlets**).
- ▶ The use of ferrules on the supply conductor wiring is recommended to further safeguard the circuit connection at the receptacle.
- ▶ Avoid clamping conductor insulation at circuit connection points.

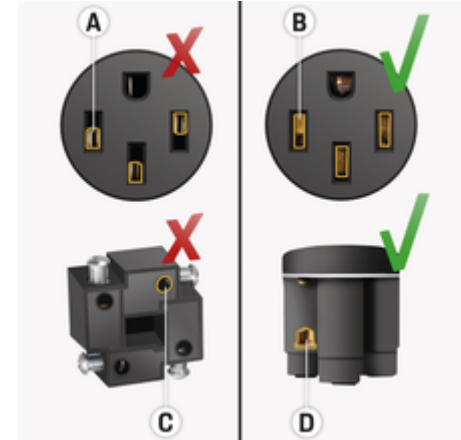
Suitable power socket/power plug typesNEMA 6-50
Outlet/PlugNema 14-50
Outlet/Plug**Requirements for the quality of the power outlets**

- A** Contact area only half the plug contact height
- B** Contact area over the full plug contact height
- C** Minimal contact area between clamping screw and stranded wire
- D** Wide contact area between clamping plate and stranded wire

Receptacles from the supplier Hubbell are recommended for their industrial quality and ability to handle high current for long periods of time.

Set up

- ▶ Hubbell HBL9450A = NEMA 14-50 Receptacle (4-prong)
- ▶ Hubbell HBL9367 = NEMA 6-50 Receptacle (3-prong)

Receptacle terminal screws must be tightened to manufacturer specifications.

The use of ferrules on the supply conductor wiring is recommended to further safeguard the circuit connection at the receptacle.

Requirements for the circuit installation

⚠ DANGER

Unsuitable wiring

Using unsuitable wiring may cause a short circuit, electric shock, explosion, fire or burns.

- ▶ The branch circuit must be protected with a 50A circuit breaker, in accordance with national and local codes and regulations.
- ▶ A 50-amp branch circuit should use a minimum 6 AWG, 90°C-rated copper wire for conductors supplying Porsche charging hardware plugged with a NEMA 14-50 or 6-50 supply cable.

Requirements for outdoor installation

⚠ DANGER

Direct contact with rain

Direct contact with rain when using the charging equipment outdoors may cause a short circuit, electric shock, explosion, fire or burns.

- ▶ Avoid direct contact between the charging equipment and rain.
- ▶ Use a rainproof NEMA 3R housing.

General precautions on (125V) supply cable use

⚠ DANGER

Emergency use only

The domestic (125V) supply cable is provided for emergency use only, and should not be used by customers for daily home charging. When used, it is recommended to limit 125V charging to a maximum of approximately 12 hours. Charge only to a minimum needed get to a nearest High-Power Charger (HPC), DC Charger, or suitable Level 2 charger for recharging.

Changing the supply cable

⚠ DANGER

Electric shock

Risk of serious or fatal injury from electric shock.

- ▶ Before changing the supply cable, always unplug the supply cable from the electrical socket and disconnect the vehicle cable from the vehicle charge port.
- ▶ Only change cables in a dry environment.
- ▶ Use the control unit with vehicle cable only in conjunction with a supply cable included in the scope of delivery or with a supply cable approved by Porsche.
 - ▷ Refer to chapter "Includes" on page 6.
- ▶ Depending on country, e.g. in Norway or Japan¹, it is **prohibited** to change the supply cable. Further information is available from your authorized Porsche dealer.



Fig. 7: Plug of the supply cable connection on the control unit

The plug of the supply cable connection is released and plugged in at the upper end of the control unit.

1. Time of printing. Further information is available from your authorized Porsche dealer.

Disconnecting the supply cable

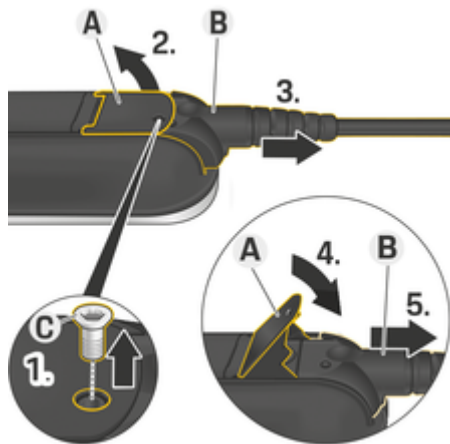

Fig. 8: Disconnecting cables

- ✓ Charging of the high-voltage battery has ended and the vehicle plug has been removed from the vehicle charge port.
 - ✓ The plug has been disconnected from the electrical socket.
1. Remove screw **C** (Fig. 8) using a suitable tool.
 2. Lift the lever **A** (Fig. 8).
 3. Pull out the plug **B** (Fig. 8) until resistance is first felt.
 4. Close the lever **A**.
 5. Pull out the plug **B** fully.

Securing supply cables and plugs

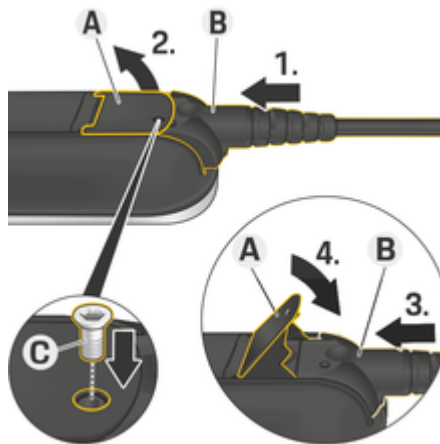

Fig. 9: Securing cables and plugs

- ✓ The lever **A** (Fig. 9) is closed.
1. Insert the plug **B** (Fig. 9) into the control unit until resistance is first felt.
 2. Lift the lever **A**.
 3. Push in the plug **B** fully.
 4. Close the lever **A**.
 5. Secure the plug **B** to the control unit using screw **C** (Fig. 9).

Operating

Operating instructions

NOTE

Risk of damage to the charger

- ▶ Always place the charger on a solid surface when charging.
- ▶ Porsche recommends using the charger in the wall mount. In some countries, e.g. Switzerland ¹, the charger may only be used in the Basic wall mount.
 - ▷ Refer to chapter "Installing the wall bracket" on page 7.
- ▶ Do **not** immerse the charger in water.
- ▶ Protect the charger from snow and ice.
- ▶ Protect the charger against potential damage through being driven over, dropped, pulled, bent or crushed.

Only operate the charger within a temperature range of -22°F to 122°F (-30°C to $+50^{\circ}\text{C}$).

i Information

- To prevent overheating during operation, do not expose the charger to continuous direct sunlight. If the operator control unit overheats, the charging process is automatically interrupted or the power is reduced until the temperature has sunk to the normal range.
- When traveling abroad, always carry the power cable suitable for the respective country.
- Depending on the country, different safety concepts with different device variants are required. Before driving abroad, ensure that the charger can also be operated in the relevant country. Check with your Porsche Partner or the local electric utility.

1. Status of printout. Check with your Porsche Partner.

Charging

Notes on charging

Vehicle charge port

For information on connecting and disconnecting the vehicle cable to and from the vehicle charge port and for the charging and connection status at the vehicle charge port:

- ▶ See Owner's Manual.

Charging times

For information about the charging times:

- ▶ See Owner's Manual.

The charging duration can vary depending on the following factors:

- Current-carrying capacity of the electrical socket used (domestic electrical socket or industrial electrical outlet)
- Country-specific power grid voltage and current
- Settings for the charging current limit on the control unit
- Fluctuations in the grid voltage
- Ambient temperature of vehicle and charger. Charging times can be longer at temperatures at the upper and lower extremes of the permitted ambient temperature.
 - ▶ Refer to chapter "Technical data" on page 22.
- Temperature of the high-voltage battery and control unit
- Passenger compartment precooling/heating activated

Information

Due to different national power grid systems, various cable variants are available. This may result in the full charging performance not being available. Further information is available from your authorized Porsche dealer.

Charging

 **DANGER**

Electric shock, fire

Risk of serious or fatal injury due to fire or electric shock.

- ▶ Always observe the specified sequence for the charging process.
- ▶ Do not disconnect the vehicle cable from the vehicle charge port during the charging process.
- ▶ End the charging process before disconnecting the vehicle cable from the vehicle charge port.
- ▶ Do not disconnect the charger from the electrical socket during the charging process.

Possible errors are displayed by the light indicators **A** – **C** (Fig. 2) by different colors, lights and flashing.

- ▶ Refer to chapter "Operating unit status indicators and error messages" on page 16.

Starting charging

1. Insert the plug into the electrical socket. All light indicators briefly light up red.
2. Insert the vehicle plug in the vehicle charge port.
 - ➔ The light indicator of the On/Off button  lights up yellow.

After a successful self-test, all light indicators light up green for 2 seconds.

For information on connecting the vehicle cable to the vehicle charge port:

- ▶ See Owner's Manual.

3. Charging starts automatically.

- ➔ The light indicator of the On/Off button  pulsates green.

Charging is controlled by the vehicle.

The charge status can be read in the vehicle.

Charging Current Limit

The operator control unit automatically detects the voltage and the available amperage. Charging current limiting can be used to set charging at full or half charging power (100% or 50%). The last charging current set is not saved. After the power plug is disconnected or after a power failure, the charging power is automatically set to 50%. To prevent overheating of the electrical installation with household cables, the charging current when using household sockets is limited to 50% on delivery.

Setting charging current limit

- ▶ Press the On/Off button  for at least 2 seconds.
 - ➔ Once the charging current limit has been set successfully, the light indicators **B** flash green (Fig. 2) once.

The set power (50% or 100%) is displayed to the left or right of the On/Off  button.

Deactivating and activating ground wire monitoring



Electric shock, short circuit, fire, explosion

Using the charger without active ground wire monitoring can cause electric shocks, short circuits, fires, explosions or burns.

- ▶ The charger must preferably be operated in grounded power grids.
- ▶ **Deactivate** ground wire monitoring only in **ungrounded** power grids (e.g. IT networks).
- ▶ **Activate** ground wire monitoring in **grounded** power grids.

▶ Refer to chapter "Activating ground wire monitoring" on page 15.

Deactivating ground wire monitoring

- ✓ The ground wire monitoring has interrupted the charging process.
- ✓ The error message about the interrupted or non-existent ground wire is shown on the control unit.

On/Off lights up red.

Power grid/house connection lights up red.

Vehicle lights up red.

Control unit is off.

Reset is off.

1. Press the buttons On/Off and Reset .

Release the buttons after the control unit light indicator has flashed six times.

2. After 1 second, press the On/Off and Reset buttons again.

Release the buttons after the control unit light indicator has flashed six times.

- ➔ The ground wire monitoring is deactivated automatically after a short time.

The status display for deactivated ground wire monitoring is displayed on the control unit:

On/Off pulses green.

Power grid/house connection lights up yellow.

Vehicle lights up yellow.

Control unit is off.

Reset is off.

Activating ground wire monitoring

- ▶ Press the buttons On/Off and Reset .





















Release the buttons after the control unit light indicator has flashed six times.





















- ➔ The illuminated yellow light indicators for power grid/house connection and vehicle go out.

The ground wire monitoring is activated automatically after a short time.





















The On/Off light indicator pulsates green.





















Operating unit status indicators and error messages

Indicator light	Meaning	Remedial action
<ul style="list-style-type: none">  On/Off lights up green.  Power supply/home connection is off.  Vehicle is off.  Operator control unit is off.  Reset is off. 	The charger is ready but not charging.	<ul style="list-style-type: none"> ▶ Start the charging process. ▶ Refer to chapter "Starting charging" on page 14.
<ul style="list-style-type: none">  On/Off pulses green.  Power supply/home connection is off.  Vehicle is off.  Operator control unit is off.  Reset is off. 	The vehicle is charging with protective ground monitoring activated.	
<ul style="list-style-type: none">  On/Off pulses green.  Power supply/home connection lights up yellow.  Vehicle is off.  Operator control unit is off.  Reset is off. 	<p>The power plug is overheated.</p> <p>Possible cause: Multi-phase electrical socket only connected in single phase.</p> <p>The charging process takes place with reduced power.</p>	<p>After power plug cools, the error is reset automatically.</p> <p>Only charging with reduced power until cooled.</p> <ul style="list-style-type: none"> ▶ If the error persists, have an electrician check the power supply/home connection.
<ul style="list-style-type: none">  On/Off pulses green.  Power supply/home connection lights up yellow.  Vehicle lights up yellow.  Operator control unit is off.  Reset is off. 	The vehicle is charging with protective ground monitoring deactivated.	<p>Ideally, charge the vehicle with protective ground monitoring activated.</p> <ul style="list-style-type: none"> ▶ Refer to chapter "Activating ground wire monitoring" on page 15.



























Indicator light	Meaning	Remedial action
<ul style="list-style-type: none">  On/Off pulses green.  Power supply/home connection is off.  Vehicle is off.  Operator control unit lights up yellow.  Reset is off. 	<p>The operator control unit is overheated.</p> <p>The charging process takes place with reduced power.</p>	<p>After the operator control unit has cooled, the error is reset automatically.</p> <p>Only charging with reduced power until cooled.</p> <ul style="list-style-type: none"> ▶ If the error persists, have the operator control unit checked by a qualified dealer/Porsche Partner.
<ul style="list-style-type: none">  On/off lights up red.  Power supply/home connection lights up yellow.  Vehicle is off.  Operator control unit is off.  Reset is off. 	<p>The power plug is overheated.</p> <p>The charging process is interrupted.</p>	<p>After the power plug has cooled, the error is reset automatically and the charging process resumes.</p> <ul style="list-style-type: none"> ▶ If the error persists, have an electrician check the power supply/home connection.
<ul style="list-style-type: none">  On/off lights up red.  Power supply/home connection is off.  Vehicle is off.  Operator control unit lights up yellow.  Reset is off. 	<p>The operator control unit is overheated.</p> <p>The charging process is interrupted.</p>	<p>After the operator control unit has cooled, the error is reset automatically and the charging process resumes.</p> <ul style="list-style-type: none"> ▶ If the error persists, have the operator control unit checked by a qualified dealer/Porsche Partner.
<ul style="list-style-type: none">  On/off lights up red.  Power supply/home connection flashes yellow.  Vehicle is off.  Operator control unit is off.  Reset is off. 	<p>The power grid/home connection charging infrastructure is restricted.</p> <p>Possible cause: Low voltage or poor power frequency.</p> <p>The charging process is interrupted.</p>	<p>After the power supply/home connection has been stabilized, the error is automatically reset and charging resumes.</p> <ul style="list-style-type: none"> ▶ If the error persists, have an electrician check the power supply/home connection.

Operating unit status indicators and error messages

Indicator light	Meaning	Remedial action
<ul style="list-style-type: none">  On/off lights up red.  Power supply/home connection is off.  Vehicle flashes yellow.  Operator control unit is off.  Reset is off. 	<p>The vehicle charging system has malfunctioned.</p> <p>The charging process is interrupted.</p>	<p>After the vehicle charging system has stabilized, the error is automatically reset and the charging process resumes.</p> <ul style="list-style-type: none"> ▶ If the error persists, have the vehicle checked by a qualified dealer/Porsche Partner.
<ul style="list-style-type: none">  On/off lights up red.  Power supply/home connection is off.  Vehicle is off.  Operating unit flashes yellow.  Reset is off. 	<p>The power supply or vehicle cable is faulty.</p> <p>Possible cause: Coding resistors of the power cable and vehicle cable do not match.</p> <p>The charging process is interrupted.</p>	<ul style="list-style-type: none"> ▶ Have the power supply or vehicle cable replaced by a qualified dealer/Porsche Partner.
<ul style="list-style-type: none">  On/off lights up red.  Power supply/home connection is off.  Vehicle lights up red.  Operator control unit is off.  Reset is off. 	<p>The vehicle charging system has malfunctioned.</p> <p>The charging process is interrupted.</p>	<ul style="list-style-type: none"> ▶ End charging process from vehicle and remove vehicle cable from the vehicle charging port. ▶ Disconnect charger from power supply and reconnect after 60 seconds. ▶ Restart charging process. <ul style="list-style-type: none"> ▷ Refer to chapter "Starting charging" on page 14. ▶ If the error persists, have the vehicle checked by a qualified dealer/Porsche Partner.
<ul style="list-style-type: none">  On/off lights up red.  Power supply/home connection flashes red.  Vehicle is off.  Operator control unit is off.  Reset is off. 	<p>The power grid/home connection charging infrastructure has overvoltage.</p> <p>The charging process is interrupted.</p>	<ul style="list-style-type: none"> ▶ Disconnect charger from power supply and reconnect after 60 seconds. ▶ If the error persists, have an electrician check the power supply/home connection.

Indicator light	Meaning	Remedial action
<ul style="list-style-type: none">  On/off lights up red.  Power supply/home connection is off.  Vehicle is off.  Operator control unit lights up red.  Reset is off. 	<p>The operator control unit has a technical fault.</p> <p>The charging process is interrupted.</p>	<ul style="list-style-type: none"> ▶ Disconnect charger from power supply and reconnect after 60 seconds. ▶ If the error persists, have the operator control unit checked by a qualified dealer/Porsche Partner.
<ul style="list-style-type: none">  On/off lights up red.  Power supply/home connection is off.  Vehicle is off.  Operator control unit flashes red.  Reset is off. 	<p>The operator control unit has a technical fault (self-test failed).</p> <p>The charging process is interrupted.</p>	<ul style="list-style-type: none"> ▶ Disconnect charger from power supply and reconnect after 60 seconds. ▶ If the error persists, have the operator control unit checked by a qualified dealer/Porsche Partner.
<ul style="list-style-type: none">  On/off lights up red.  Power supply/home connection lights up red.  The vehicle lights up red.  Operator control unit is off.  Reset is off. 	<p>The power grid/home connection charging infrastructure is insufficient: The protective ground is interrupted or not present.</p> <p>Protective ground monitoring has interrupted the charging process.</p>	<ul style="list-style-type: none"> ▶ Only ungrounded power grids (e.g. IT networks): If necessary, charge the vehicle with protective ground monitoring deactivated. <ul style="list-style-type: none"> ▶ Refer to chapter "Deactivating ground wire monitoring" on page 15. ▶ Only grounded power grids: Have the operator control unit checked by a qualified dealer/Porsche partner and the power grid/home connection by an electrician.
<ul style="list-style-type: none">  On/off lights up red.  Power supply/home connection lights up red.  The vehicle lights up red.  Operator control unit lights up red.  Reset is off. 	<p>The indicator light for the operator control unit Reset button is faulty.</p> <p>The charging process is interrupted.</p>	<ul style="list-style-type: none"> ▶ Have the operator control unit replaced by a qualified dealer/ Porsche Partner.

Operating unit status indicators and error messages

Indicator light	Meaning	Remedial action
<ul style="list-style-type: none">  On/off lights up red.  Power supply/home connection lights up red.  The vehicle lights up red.  Operator control unit lights up red.  Reset flashes red. 	<p>The operator control unit has detected a fault current.</p> <p>The charging process is interrupted.</p>	<ul style="list-style-type: none"> ▶ Press Reset button  for at least 2 seconds. ▶ If the error persists, have the operator control unit checked by a qualified dealer/Porsche Partner and the power supply/home connection by an electrician.
<ul style="list-style-type: none">  On/off lights up red.  Power supply/home connection flashes red.  Vehicle flashes red.  Operator control unit flashes red.  Reset is off. 	<p>The charging infrastructure is wired incorrectly.</p> <p>The charging process is interrupted.</p>	<ul style="list-style-type: none"> ▶ Disconnect charger from power supply. ▶ Have the power supply/home connection checked by an electrician.
<ul style="list-style-type: none">  On/off lights up red.  Power supply/home connection lights up red.  The vehicle lights up red.  Operator control unit lights up red.  Reset lights up red. 	<p>The operator control unit has a technical fault.</p> <p>Possible cause: Software error or load relay switched incorrectly.</p> <p>The charging process is interrupted.</p>	<ul style="list-style-type: none"> ▶ Disconnect charger from power supply and reconnect after 60 seconds. ▶ If the error persists, have the operator control unit checked by a qualified dealer/Porsche Partner and the power supply/home connection by an electrician.
<ul style="list-style-type: none">  On/Off flashes red.  Power supply/home connection is off.  Vehicle is off.  Operator control unit lights up red.  Reset is off. 	<p>The operator control unit has a serious defect.</p> <p>The charging process is interrupted.</p>	<ul style="list-style-type: none"> ▶ Have the operator control unit replaced by a qualified dealer/ Porsche Partner.
<ul style="list-style-type: none">  On/Off is off.  Power supply/home connection lights up red.  The vehicle lights up red.  Operator control unit lights up red.  Reset lights up red. 	<p>The indicator light for the On/Off button on the operator control unit is defective.</p> <p>The charging process is interrupted.</p>	<ul style="list-style-type: none"> ▶ Have the operator control unit replaced by a qualified dealer/ Porsche Partner.

Transport

⚠ WARNING

Unsecured load

An unsecured, incorrectly secured or incorrectly positioned charger can slip out of place and endanger occupants when braking, accelerating, changing direction or in the event of an accident.

- ▶ Never transport the charger unsecured.
- ▶ Stow the charger in the charging bag in the luggage compartment.
- ▶ Always transport the charger in the luggage compartment, never in the passenger compartment (e.g. on or in front of the seats).

For information on the tie-down rings in the luggage compartment:

- ▶ Follow vehicle instructions.

Securing bag

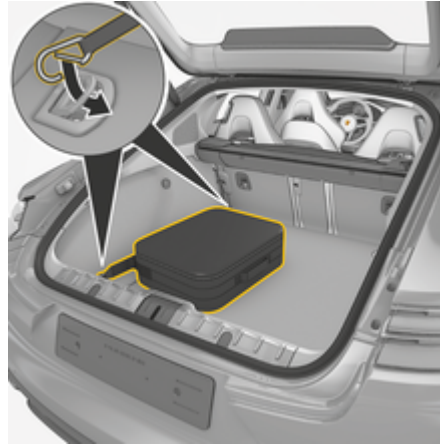

Fig. 10: Securing bag (e.g. Panamera 4 E-Hybrid)

- ▶ Hook bag to the front and rear tie-down rings.

Cleaning and maintenance

Check the charger regularly for damage and dirt and clean if necessary.

⚠ DANGER

Electric shock, fire

Risk of serious or fatal injury due to fire or electric shock.

- ▶ Never immerse the charger or plugs in water or spray them directly with water (e.g. high-pressure cleaning equipment or garden hoses).
- ▶ Only clean the charger when the control unit has been fully disconnected from the power grid and from the vehicle. Use a dry cloth for cleaning.

Disposal of the product



Electrical/electronic devices and batteries can be deposited at a collection point or a waste disposal facility.

- ▶ Do not throw electrical/electronic devices or batteries into household waste.
- ▶ Dispose of electrical/electronic devices and batteries in accordance with the applicable environmental regulations.
- ▶ If you have any questions about disposal, please contact a Porsche Partner .

Technical data

Electrical data 9Y0.971.675...	BA MCB36U1 x ¹	BB MCB96U1 x ¹
Power	3.6 kW	9.6 kW
Rated current	16 A, 1-phase	40 A, 1-phase
Power supply voltage	120 V – 240 V, 120 V to ground	120 V – 240 V, 120 V to ground
Power frequency	50 Hz/60 Hz	50 Hz/60 Hz
Overvoltage category (EN 60664)	II	II
Rated short-time current resistance (EN 61439-1)	< 10 kA eff.	< 10 kA eff.
Integrated residual-current device	Type A (AC: 20 mA) + DC: 56 mA	Type A (AC: 20 mA) + DC: 56 mA
Vehicle charging plug	Type 1	Type 1
Protection class	I	I
Protection type	IP55 (NEMA 3)	IP55 (NEMA 3)

1. The “x” stands for pending design changes and may be any letter.

Mechanical data

Control unit weight	5.3 – 7.7 lbs (2.4 – 3.5 kg)
Wall bracket dimensions	5.4 in (136 mm) x 15.4 in (391 mm) x 3.0 in (76 mm) (width x height x depth)
Wall bracket weight	approx. 1lb (450 g)
Cable guide dimensions	5.0 in (127 mm) x 5.5 in (139 mm) x 4.5 in (115 mm) (width x height x depth)
Cable guide weight	approx. 0.9 lbs (420 g)
Connector holder dimensions	5.4 in (136 mm) x 6.8 in (173 mm) x 2.0 in (50 mm) (width x height x depth)
Plug holder weight	approx. 0.3 lbs (140 g)
Complete basic wall bracket weight	approx. 2 lbs (1 kg)

Ambient and storage conditions

Ambient temperature	-22° F to 122° F (-30° C to +50° C)
Humidity	5% – 95% non-condensing
Altitude	max. 13,120 ft (4,000 m) above sea level

Type plate Mobile charger

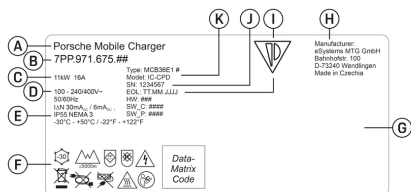

Fig. 11: Type plate (example)

- A** Product name
- B** Article number
- C** Power and rated current
- D** Power supply voltage
- E** Protection type
- F** Operation pictograms
- G** Certification information
- H** Manufacturer
- I** Date of manufacture
- J** Serial number
- K** Type designation

Production information

Date of manufacture

The charger's date of manufacture is found on the type plate behind the abbreviation "EOL".

The following format is used: Production day.Production month.Production year

Manufacturer of the charger

Aptiv Services Deutschland GmbH
Am Technologiepark 1
42119 Wuppertal

Germany
Phone +49 202 291 0

Electrical tests

If you have questions about the regular electrical inspection of the charging infrastructure (e.g. VDE 0702) please visit <https://www.porsche.com/international/accessoriesandservice/porscheservice/vehicleinformation/documents/> or contact a Porsche Partner.

Brazil



03725-21-12707

Este equipamento opera em caráter secundário, isto é, não tem direito a proteção contra interferência prejudicial, mesmo de estações do mesmo tipo, e não pode causar interferência a sistemas operando em caráter primário". Para maiores informações, consulte o site da ANATEL www.anatel.gov.br

Index

C

Charge status.....	14
Charging cable	
cable and connector types.....	9
Plugging in/unplugging.....	14
Charging current limiting.....	14
Charging times.....	14
Cleaning.....	21
Connection status.....	14
Control unit	
Inserting in wall bracket.....	8
Overview.....	6
Control unit overview.....	6

D

Date of manufacture.....	24
Disposal of the product.....	21

E

Electrical sockets	
Household.....	10
Industrial.....	10
Error messages.....	16

G

General safety instructions.....	4
Ground wire monitoring	
Activating.....	15
Deactivating.....	15

H

Household electrical sockets.....	10
-----------------------------------	----

I

Includes.....	6
Indicator light.....	16

Industrial electrical sockets.....	10
Installing the plug holder.....	8
Intended Use.....	6

L

Limitation of Charging Current.....	14
-------------------------------------	----

M

Maintenance.....	21
Manufacturer.....	24
Mounting standard wall bracket.....	7

O

Operating instructions.....	13
Operator control unit	
Pictograms.....	3

P

Pictograms.....	3
Power cable	
Selecting.....	9
Power cable selection.....	9
Production information.....	24

R

Required tools.....	7
---------------------	---

S

Safety instructions.....	4
Selecting the installation location.....	7
Serial number.....	24
Starting charging.....	14
Structure of warning notes.....	1
Supply cable	
Changing.....	12
Symbols in this manual.....	1

T

Technical data.....	22
Tool box.....	7
Transporting charger.....	21
Transporting the charger.....	21
Type plate.....	24

V

Vehicle charging cable	
cable and connector types.....	9
Plugging in/unplugging.....	14